

U.S. Department of Transportation  <b>United States Coast Guard</b>		Commandant (G-MTH-3) United States Coast Guard	MAILING ADDRESS: 2100 SECOND STREET SW WASHINGTON DC 20593-0001 202) 267-2988
--	---	---	--

COMDTPUB P16700.4  
NVIC 4-93  
MAY 25, 1993

NAVIGATION AND VESSEL INSPECTION CIRCULAR NO. 4-93  
Subj: Subdivision and Damage Stability of Dry Cargo Vessels

1. PURPOSE. The purpose of this Circular is to promulgate International Maritime Organization (IMO) Resolution A.684(17), "Explanatory Notes to the SOLAS Regulations on Subdivision and Damage Stability of Dry Cargo Ships of Over 100 Meters (328 feet) in Length."
2. BACKGROUND.
  - a. In 1985, the Maritime Safety Committee (MSC) of the IMO instructed the technical Sub-Committee on Stability and Load Lines and on Fishing Vessels Safety (SLF) to develop a subdivision and damage stability standard based on the probabilistic analysis method. The standards that were developed are based on the research work done for the probabilistic rules for passenger ships (IMO Resolution A.265(VIII)).
  - b. IMO Resolution MSC.19(58), "Regulations for the Damage Stability Requirements of Dry Cargo Ships," became effective on February 1, 1992, as an amendment to the International Convention for the Safety of Life at Sea, 1974 (SOLAS). The U.S. Coast Guard published a final rule (58 FR 17316) on April 1, 1993, which adopted this international standard into 46 CFR Part 174.
  - c. The SLF Sub-Committee developed the consolidated text of the explanatory notes to the regulation on subdivision and damage stability of dry cargo ships which was published as Resolution A.684(17).
3. DISCUSSION.
  - a. The probabilistic approach of the regulations takes into account the probability of various extents of damage occurring anywhere along the ship's length and the resulting flooding. At the same time it takes into account the probability that the ship will survive the damage given its stability and draft. This provides a rational means of assessing the safety of ships, where flooding is concerned, no matter what their arrangements might be. For instance, a ship may be designed with less subdivision in part of its length, provided it has

additional subdivision in areas shown to have a higher probability of damage. In this respect, it frees designers and operators from unnecessarily arbitrary restrictions on arrangements.

b. This Circular is initial guidance for the marine shipping industry, ship designers, and the U.S. Coast Guard. As experience with the probabilistic method is gained this information will be updated accordingly.

c. Any questions concerning the regulations on subdivision and damage stability should be directed to the U.S. Coast Guard's Marine Safety Center (MSC). The MSC will review all questions from the civilian marine industry concerning the new regulations on subdivision and damage stability and will consult with the U.S. Coast Guard's Marine Technical Hazardous Materials Division if further clarification is necessary.

#### 4. IMPLEMENTATION.

a. Enclosure (1), IMO Resolution A.684(17), has been promulgated as international policy to assist interpretation of the SOLAS regulations on the subdivision and damage stability of dry cargo vessels including Ro/Ro ships of over 100 meters (328 feet) in length. These explanatory notes shall be used in conjunction with both part B-1 of chapter zz-1 of SOLAS 1974 and 46 CFR 174.

/s/

R. C. NORTH

ACTING CHIEF, OFFICE OF MARINE SAFETY,  
SECURITY & ENVIRONMENTAL PROTECTION

Encl: (1) IMO Resolution A.684(17)

Non-Standard Distribution:

C:e New Orleans (90); Hampton Roads (50); Baltimore (45); San Francisco (40); Philadelphia, Port Arthur, Honolulu, Puget Sound (35); Miami, Houston, Mobile, Morgan City, Los Angeles/Long Beach, Portland OR (25); Jacksonville (20); Boston, Portland NE, Charleston, Galveston, Anchorage (15); Cleveland (12); Louisville, Memphis, Paducah, Pittsburgh, St. Louis, San Juan, Savannah, Tampa, Chicago, Buffalo, Detroit, Duluth, Milwaukee, San Diego, Juneau, Valdez (10); Providence, Huntington, Wilmington, Corpus Christi, Toledo, Guam (5).

C:m New York (70); St. Ignace (5); Sturgeon Bay (4).

D:d Except Baltimore, Moriches.

D:1 CG Liaison Officer MILSEALIFTCOMD (Code N-7CG), CG Liaison Officer RSPA (DHM-22), CG Liaison Officer FARAD (MAR-742), CG Liaison Officer JUSMAGPHIL, CG Liaison Officer World

Maritime University, CG Liaison Officer ABS (1).

ABS (260).

NOAA Fleet Inspection Officer (1).

U.S. Merchant Marine Academy (1).

**Resolution A.684(17)**  
**Adopted on 6 November 1991**  
**(Agenda item 10)**

**EXPLANATORY NOTES TO THE SOLAS REGULATIONS  
ON SUBDIVISION AND DAMAGE STABILITY  
OF CARCO SHIPS OF 100 METRES IN LENGTH AND OVER**

THE ASSEMBLY,

Recalling Article 15(j) of the Convention on the International Maritime Organization concerning the functions of the Assembly in relation to regulations and guidelines concerning maritime safety,

Recalling further that by resolution A.265(VIII) the Assembly adopted regulations on subdivision and stability of passenger ships, which may be used as an equivalent to part B "Subdivision and stability" oil chapter II-1 of the 1974 SOLAS Convention,

NOTING that by resolution MSC.19(58) the Maritime Safety Committee at its fifty-eighth session adopted amendments to the 1974 SOLAS Convention to include, as part B-1 of chapter II-1. Regulations for subdivision and damage stability of cargo ships which apply to cargo ships of 100 m in length and over,

Nothing further that the Maritime Safety Committee, in adopting the above amendments to the 1974 SOLAS Convention, recognized the necessity of development of appropriate explanatory notes for implementation of the regulations adopted, in order to ensure their uniform application,

Having considered the recommendations made by the Maritime Safety Committee at its fifty-ninth session,

1. Adopts the explanatory notes to the SOLAS regulations on subdivision and damage stability of cargo ships of 100 m in length and over set out in the annex to the present resolution;
2. Invites Governments to apply the explanatory notes when implementing the regulations for subdivision and damage stability contained in the amendments to chapter II-1 of the 1974 SOLAS Convention adopted by resolution MSC.19(5S).

**Annex**

**EXPLANATORY NOTES TO THE SOLAS REGULATIONS  
ON SUBDIVISION AND DAMAGE STABILITY  
OF CARGO SHIPS OF 100 METRO IN LENGTH AND OVER**

These explanatory notes are divided into two parts. Part A describes the background to the method used while part B contains explanations and amplifications of individual regulations.

In this part of the explanatory notes, the background of the subdivision index is presented and then the calculation of the probability of damage is developed.

Finally, the development of the calculation of the probability that a damaged ship will not capsize or sink is demonstrated.

## 1 INTRODUCTION

The SOLC regulations on subdivision and damage stability, as contained in part B-1 of SOLAS chapter II-1, are based on the probabilistic concept which takes the probability of survival after collision as a measure of ship's safety in the damaged condition, hereinafter referred to as the "attained subdivision index A".

This is an objective measure of ship safety and therefore there is no need to supplement this index by any deterministic requirements. These new regulations, therefore, are primarily based on the probabilistic approach, with only very few deterministic elements which are necessary to make the concept practicable.

The philosophy behind the probabilistic concept is that two different ships with the same index of subdivision are of equal safety and therefore there is no need for special treatment for specific parts of the ship. The only areas which are given special attention in these regulations are the forward and bottom regions which are dealt with by special rules concerning subdivision, provided for the cases of ramming and grounding.

In order to develop the probabilistic concept of ship subdivision, it is assumed that the ship is damaged. Since the location and size of the damage is random. It is not possible to state which part of the ship becomes flooded. However, the probability of flooding a space can be determined if the probability of occurrence of certain damages is known. The probability of flooding a space is equal to the probability of occurrence of all such damages which just open the considered space. A space is a part of the volume of the ship which is bounded by undamaged watertight structural divisions.

Next, it is assumed that a particular space is flooded. In addition to some inherent characteristics of the ship, in such a case there are various factors which influence whether the ship can survive such flooding; they include the initial draught and GM, the permeability of the space and the weather conditions, all of which are random at the time when the ship is damaged. Provided that the limiting combinations of the aforementioned variables and the probability of their occurrence are known, the probability that the ship will not capsize or sink, with the considered space flooded can be determined.

The probability of survival is determined by the formula for entire probability as the sum or the products for each compartment or group of compartments of the probability that a space is flooded multiplied by the probability that the ship will not capsize or sink with the considered space flooded.

Although the ideas outlined above are very simple, their practical application in an exact manner would give rise to several difficulties. For example, for an extensive but still incomplete description of the damage, it is necessary to know its longitudinal and vertical location as well as its longitudinal,

vertical and transverse extent. Apart from the difficulties in handling such a five-dimensional random variable, it is impossible to determine its probability distribution with the presently available damage statistics. Similar conditions hold for the variables and physical relationships involved in the calculation of the probability that a ship with a flooded space will not capsize or sink.

In order to make the concept practicable, extensive simplifications are necessary. Although it is not possible to calculate on such a simplified basis the exact probability of survival, it is possible to develop a useful comparative measure of the merits of the longitudinal, transverse and horizontal subdivision of the ship.

## 2 DETERMINATION OF THE PROBABILITY OF FLOODING OF SHIP SPACES

### 2.1 Consideration of longitudinal damage location and extent only

The simplest case is to consider the location and length of damage in the longitudinal direction. This would be sufficient for ships with no longitudinal and horizontal watertight structural divisions.

With the damage location  $x$  and damage length  $y$  as defined in figure 1, all possible damages can be represented by points in a triangle which is also shown in this figure.

All damages which open single compartments of length  $l_i$  are represented in figure 1 by points in triangles with the base  $l_i$ . Triangles with the base  $l_i + l_j$  (where  $j=i+1$ ) enclose points corresponding to damages opening either compartment  $i$ , or compartment  $j$ , or both of them. Correspondingly, the points in the parallelogram  $ij$  represent damages which open both the compartments  $i$  and  $j$ .

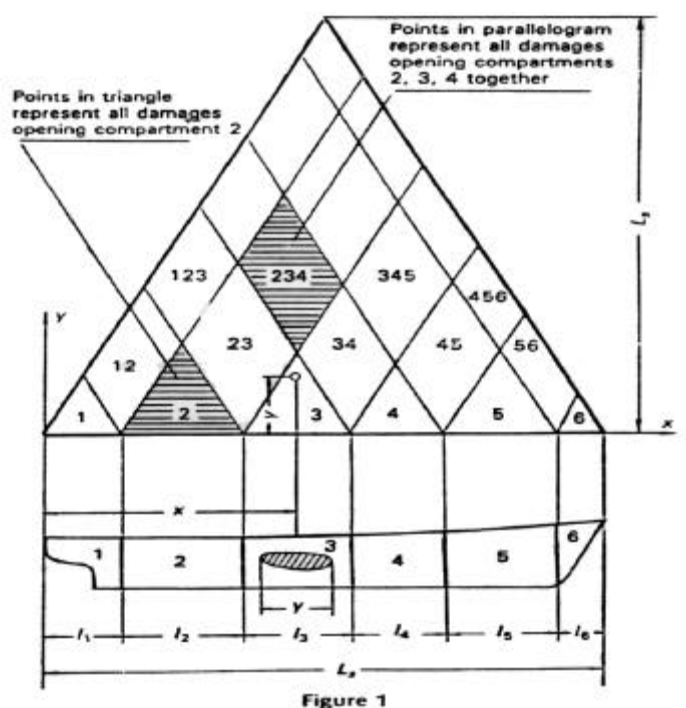

Figure 1

Damage location  $x$  and damage length  $y$  are random variables. Their distribution density  $f(x,y)$  can be derived from the damage statistics. The meaning of  $f(x,y)$  is as follows (see figure 2): the total volume between the  $x$ - $y$  plane and the surface given by  $f(x,y)$  equals one and represents the probability that there is damage (this has been assumed to be certain). The volume above a triangle corresponding to damage which opens a compartment represents the probability that this compartment is opened. In a similar manner for all areas in the  $x$ - $y$  plane which correspond to the opening of compartments or group of compartments, there are volumes which represent the probability that the considered compartments or group of compartments are opened.

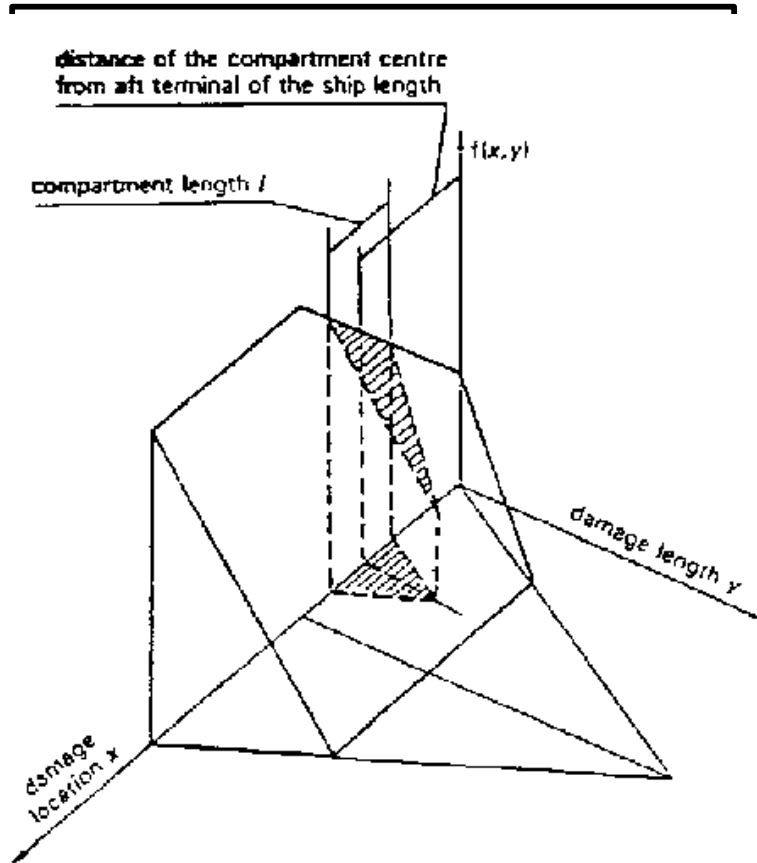

Figure 2

The probability that a compartment or a group of adjacent compartments is opened is expressed by the floor  $p_i$  as calculated according to regulation 25-5.

Consideration of damage location  $x$  and damage length  $y$  only would be fully correct in the case of ships with pure transverse subdivision. However, there are very few, if any, such ships -- all normally have a double bottom, at least.

In such a case, the probability of flooding a compartment should be split up into the following three components: probability of flooding the double bottom only, probability of flooding the space above the double bottom only and

probability of flooding both the space above and the double broom itself (see figure 3). For each of these cases there may be a different probability that the ship will survive in the <loaded condition. A way out of this dilemma, which may be used in applying these new regulations, is to assume that the most unfavorable vertical extent of damage (out of the three possibilities) occurs with the total probability  $p$ . therefore the contribution to survival probability made by more favorable cases is neglected. That the concept is still meaningful for comparative purposes follow from the fact that the error made by neglecting favorable effects of horizontal subdivision is not great and the more important influence of longitudinal damage location and extension is fully covered.

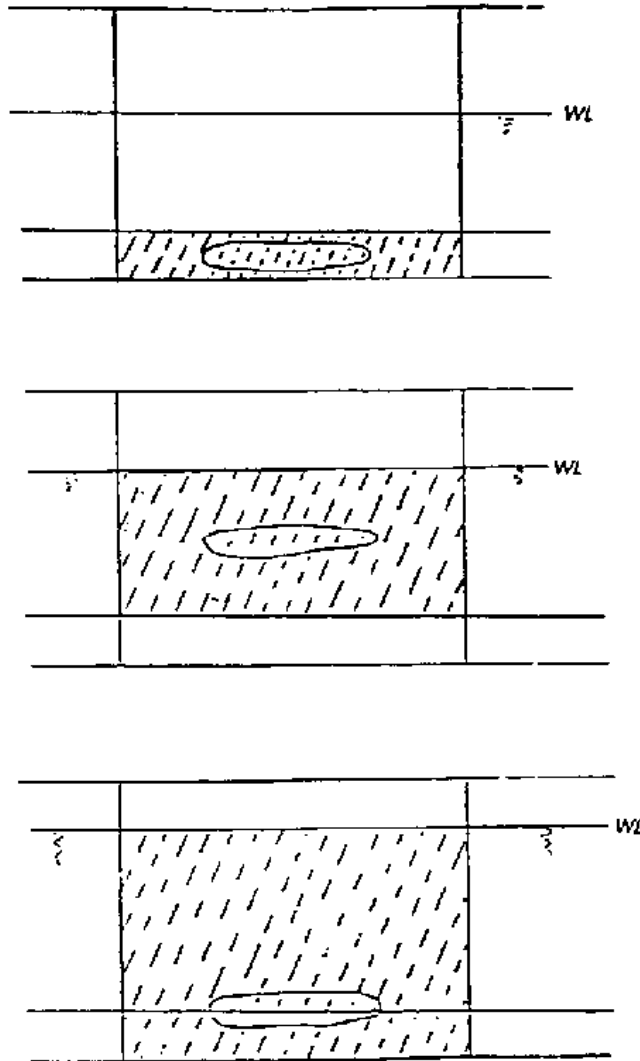

Figure 3

Some example: for dealing with other cases of horizontal subdivision are given in appendix 1.

## 2.2 Consideration of horizontal subdivision above a waterline



In the case where the ship has a horizontal subdivision above a waterline, the vertical extent of damage may be limited to the depth of that horizontal subdivision. The probability of not damaging the horizontal subdivision is represented by the factor  $v$ , as calculated according to regulation 25-6. This factor represents the assumed distribution function of the vertical extent of damage and varies from zero for subdivision at the level of the waterplane, linearly upwards to the value of one at the level conforming to the minimum bow height according to the 1966 Load Line Convention (see figure 4).

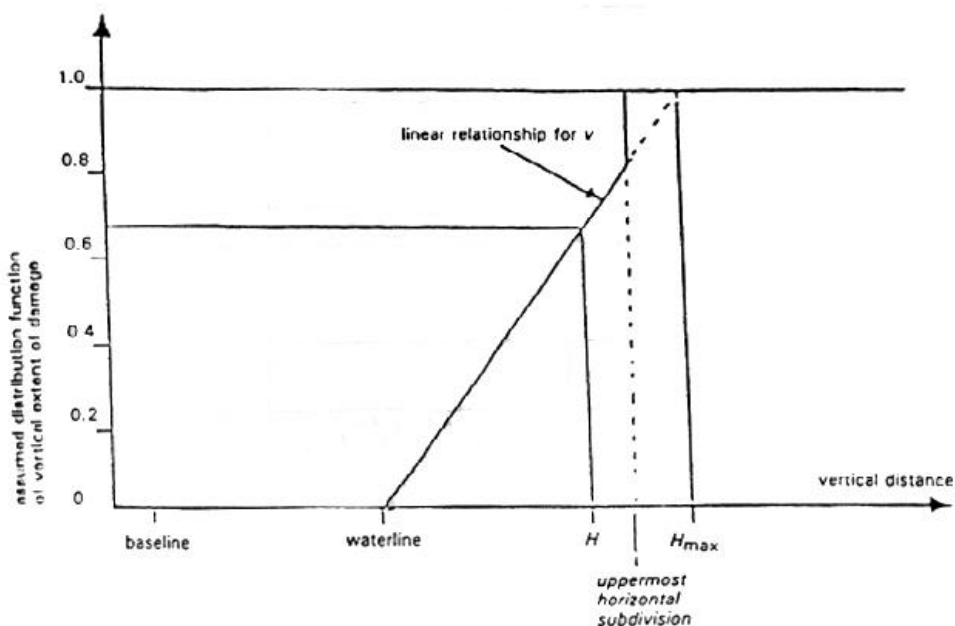

Figure 4

### 2.3 Consideration of damage penetration in addition to longitudinal damage location and extent

With the simplifying assumption that the damage is rectangular and with the vertical extent of damage according to 2.2, the damage can be described by the damage location  $x$ , the damage length  $y$  and the damage penetration  $z$  (see figure 5). These variables can be represented in a three-dimensional co-ordinate system, as shown in figure 6. Each point in the prism, with triangular base, represents a damage.

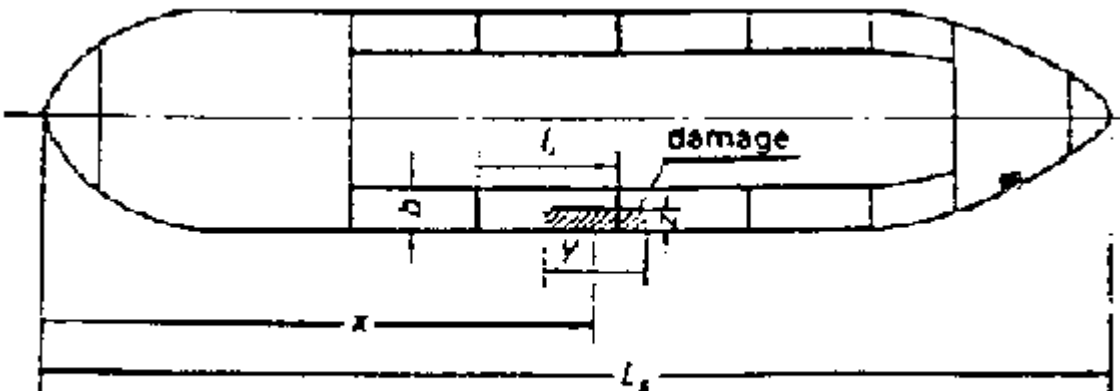

Figure 5

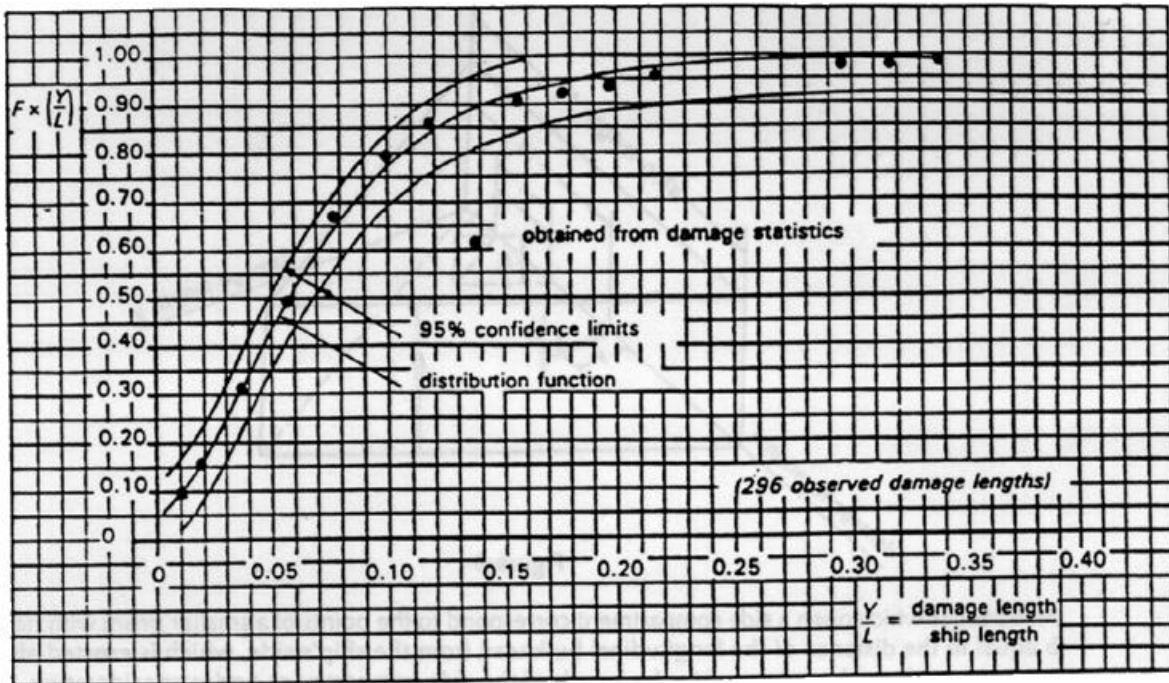

Figure 7 - Distribution function of nondimensional damage length

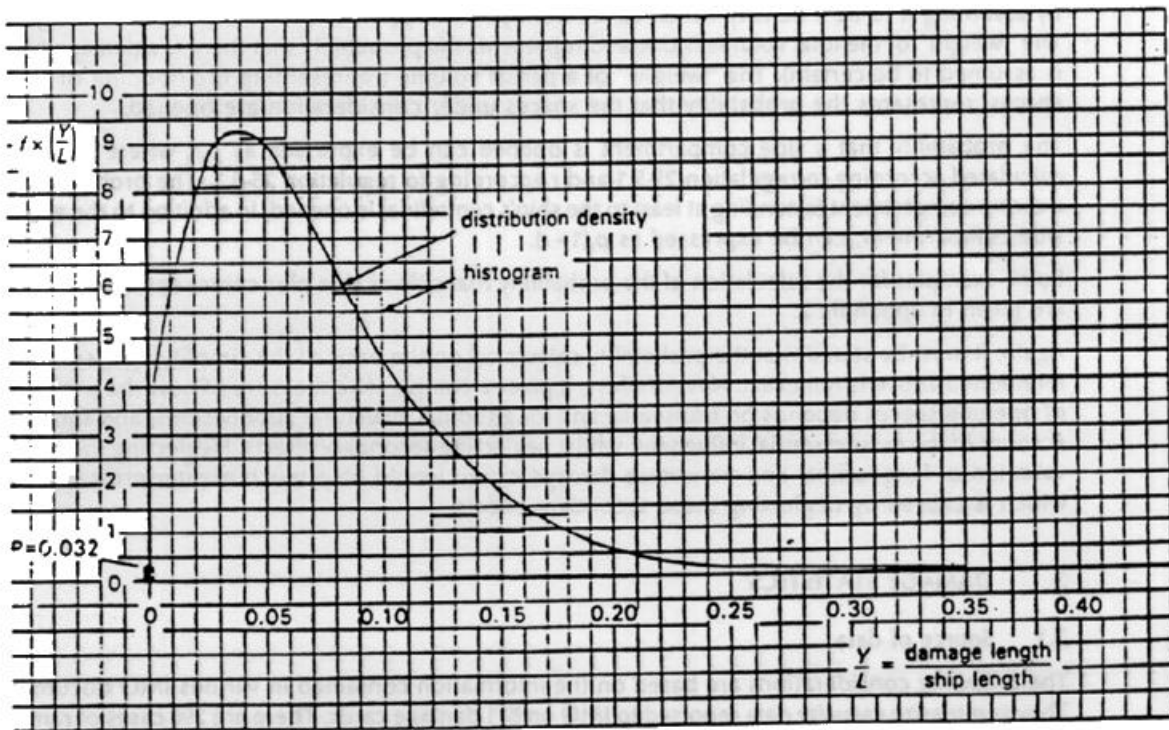

Figure 8 - Distribution density of nondimensional damage length

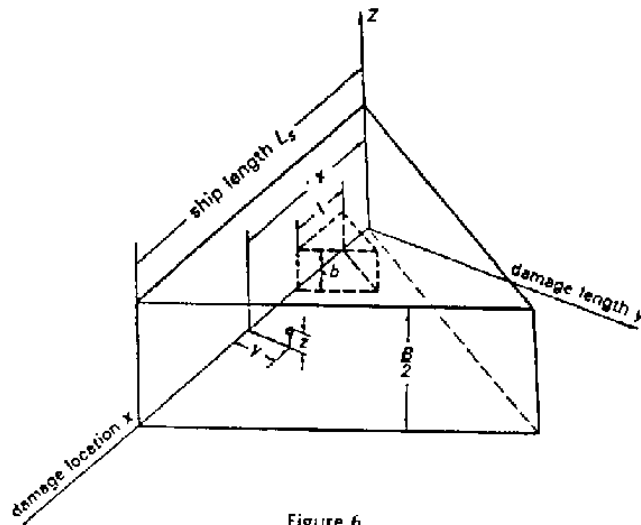

Figure 6

All damages which open a side compartment correspond to the points of a smaller prism with height  $b$  equal to the distance of the longitudinal bulkhead from the ship's side, which is erected above a triangle with the base  $l_i$  equal to the length of the side compartment under consideration. It is not difficult to identify in figure 5 the volumes which correspond to such damage which flood other parts of the ship bounded by transverse and longitudinal watertight structural subdivisions.

Damage location  $x$ , damage length  $y$  and damage penetration  $z$  are random variables. The distribution density  $f(x,y,z)$  can be derived from damage statistics. This distribution density can be illustrated by assuming it to be a density which varies from point to point of the volume shown in figure 6. The "weight" of the total volume is one and represents the probability that there is a damage (which is assumed to be certain). The "weight" of a partial volume (representing the flooding of certain spaces) represents the probability that the spaces under consideration are opened.

The probability that a side compartment is opened can be expressed as  $p_i r$ , where  $p_i$  is to be calculated according to regulation 25-5.1 and  $r$  according to regulation 25-5.2. The probability that a center compartment (extending at least to the ship's centerline) is opened, in addition to the adjacent side compartment, can be expressed as  $p_i(1-r)$ .

Some examples for the calculation of the probability that side or side plus center spaces are opened are given in appendix 2.

Again, it must be stated that the probability calculated on the basis of the simplifying assumptions mentioned are is not exact. Nevertheless, it gives a comparative measure of how the probability of opening spaces depends on transverse and longitudinal structural subdivisions, and thus takes account of the most essential influences, whilst neglecting secondary effects. Neglecting the random variation of longitudinal and transverse damage event would be a much greater error than that which is caused by neglecting these secondary effects.

### 3 DAMAGE STATISTICS

#### 3.1 Source of data

The following considerations are based on the information contained in various IMO documents. They summarize casualty data reported to IMO on 811 damage cards. There are 296 cases of rammed ships which contain information on each of the following characteristics:

Ship length- L  
Ship breadth - B  
Damage location - x  
Damage length - y  
Damage penetration - z

In order to omit inconsistencies in the results derived from the data, which may be caused by the use of different samples, the following investigations have been based only on the aforementioned 296 cases. However, further investigations have been made using, in addition, the information given for other cases. Despite the random scatter, which is to be expected because of the use of different samples composed at random, they lead to the same conclusion.

For the investigation of the dependency of damage length on the year of collision, a different sample was used comprising 209 cases in which L, y and year of collision were given.

### **3.2 General consideration of damage extent**

It is clear that the principal factors affecting damage extent are:

- .1 structural characteristics of the rammed ship;
- .2 structural characteristics of the ramming ship;
- .3 mass of the rammed ship at time of collision;
- .4 mass of the ramming ship at time of collision;
- .5 speed of the rammed ship at time of collision;
- .6 speed of the ramming ship at time of collision;
- .7 relative course angle between rammed and ramming ship;
- .8 location of damage relative to the ship's length.

From the point of view of the rammed ship only item .1 is pre-determined; all other items are random. An investigation of the damage length of ships with different numbers of decks has shown that there is no significant influence. This does not prove that there is no influence. It is, however, valid to conclude that the influence of structural characteristics is relatively small. It therefore seems justifiable to neglect this influence.

The mass of the rammed ship depends on its size and its loading condition. The influence of the latter is small and therefore for the sake of simplicity it has been neglected. To account for the size of the rammed ship, damage length has been related to the ship length and damage penetration to the ship breadth.

The following will show that the damage length does not depend significantly on the place at which it occurs in the ship's length. From this it is concluded that the damage extent does not depend on the location of the damage, except at the ends of the ship where damage length is bounded according to the definition of damage location as the center of the damage.

Some comments on the mass of the ramming ship are given below.

### **3.3 Distribution of damage length**

Preliminary investigations have led to the conclusion that the distribution of the ratio damage length to ship length  $y/L$  is more or less independent of the ship length. A proof will be given below. As a consequence,  $y/I$  can be taken as independent of  $L$ .

From theoretical considerations (using the central limit theorem) it follows that  $y/L + e_y$  (where  $e$  is constant) is approximately log-normally distributed. This is confirmed by figures 7 and 8, in which good agreement is shown between the log-normal distribution function and distribution density on the one hand and the corresponding results of the damage statistics on the other.

.2 ships where the side shell has been significantly strengthened by the provision of a double skin inhere it may be agreed to use enhanced values of the reduction factor  $r$  (regulation 25-5.2). In such a case, supporting calculations indicating the superior energy-absorbing characteristics of the structural arrangement are to be provided;

.3 vessels of a multi-hull design, where the subdivision arrangements would need to be evaluated against the basic principles of the probabilistic method since the regulations have been written specifically for mono-hulls.

#### Regulation 25-2

##### Paragraph 1.2

This definition does not preclude loading the ship to deeper draughts permissible under other load line assignment' such as tropical, timber, etc.

##### Paragraph 1.3

The light ship draught is the draught, assuming level trim, corresponding to the ship lightweight. Lightweight is the displacement of a ship in tons without cargo, fuel, lubricating oil, ballast water, fresh water and feed water in tanks, consumable stores, and passengers and crew and their effects. The draught corresponding to the partial load line is given by the formula:

$$d_p = d_{1s} - 0.6(d_1 - d_{1s})$$

where:

$d_p$  = draught corresponding to the partial load line (m);

$d_1$  = draught corresponding to the deepest subdivision load line (m)

$d_{1s}$  = light ship draught; (m)

##### Paragraph 2.1

The definition of  $L_s$  2.1 of regulation 25-2 is illustrated in figure 21.

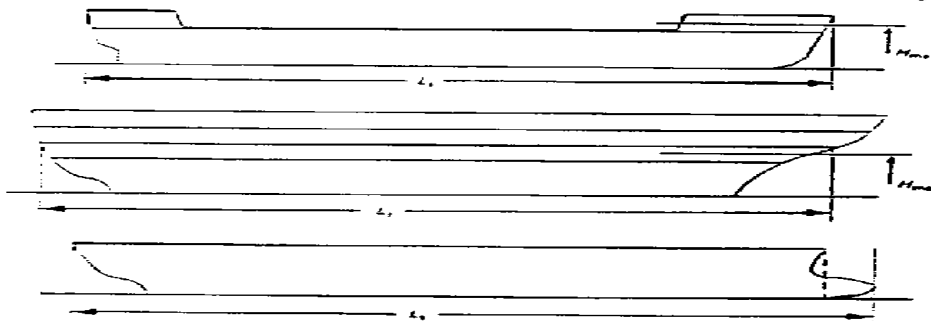

Figure 21 - Illustration of the definition  $\pi L$ , according to paragraph 2.1 of regulation 25-2

Figure 9 shows the regression of  $y/L$  on  $L$  for  $L < 200$  m (five damages relate to ships with  $L > 200$  m). The regression line has a small negative slope which proved to be insignificant, and may be caused by sample taken at random. There might be a small dependence of  $y/L$  on the ship length, but it is so small that it cannot be derived from the given sample. It is therefore certainly no

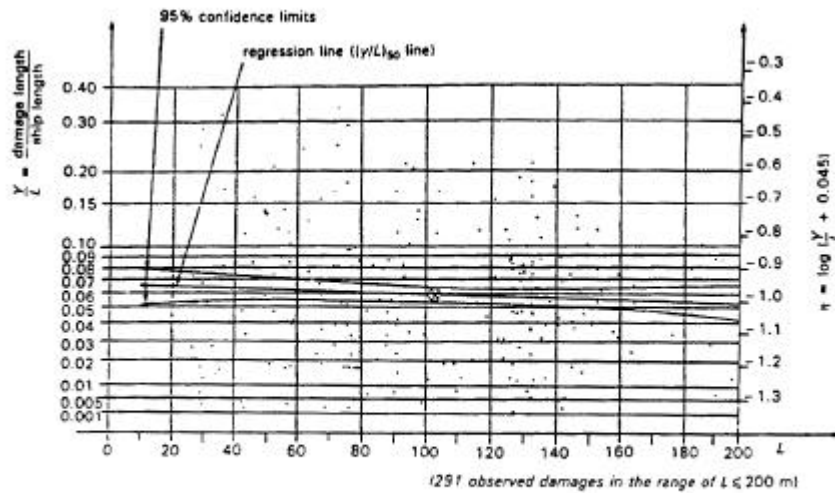

Figure 9 - Regression of nondimensional damage length on ship length

significant error to assume  $y/L$  to be independent of ship size for  $L < 200$  m. An explanation of this independence might be that small vessels are more likely to meet mainly small vessels and large vessels are more likely to meet mainly large vessels. However, this reasoning cannot be extended to very large vessels because of the small total number of such ships. Because of the very low damage cases concerning ships with  $L > 200$  m, nothing can be said about the damage distribution of such ships. (It seems reasonable to assume, as an approximation for ships with  $L > 200$  m, that the median of the damage length is constant and equal to the median for  $L = 200$  m. The latter equals  $200 \times (y/L)_{50}$ , where  $(y/L)_{50}$  is the median of the non-dimensional damage length for ships with  $L = 200$  m.

The regression of the non-dimensional damage length  $y/L$  on the non-dimensional damage location is given in figure 10. This shows that there is no significant difference between the damage distributions in the forward and aft half of the ship, but simple geometric reasoning indicates that the damage length at the ends of the ship - forward as well as aft - is limited to smaller values than in the central part of the ship. Therefore the log-normal distribution found for all values for  $y/L$  - independent of damage location - is the marginal distribution. The corresponding conditional distribution of  $y/L$ , on the condition that the damage location is given, does not need to be considered as for the practical application an approximation will be used, which allows establishment of a very simple relationship between the conditional and marginal damage length distribution.

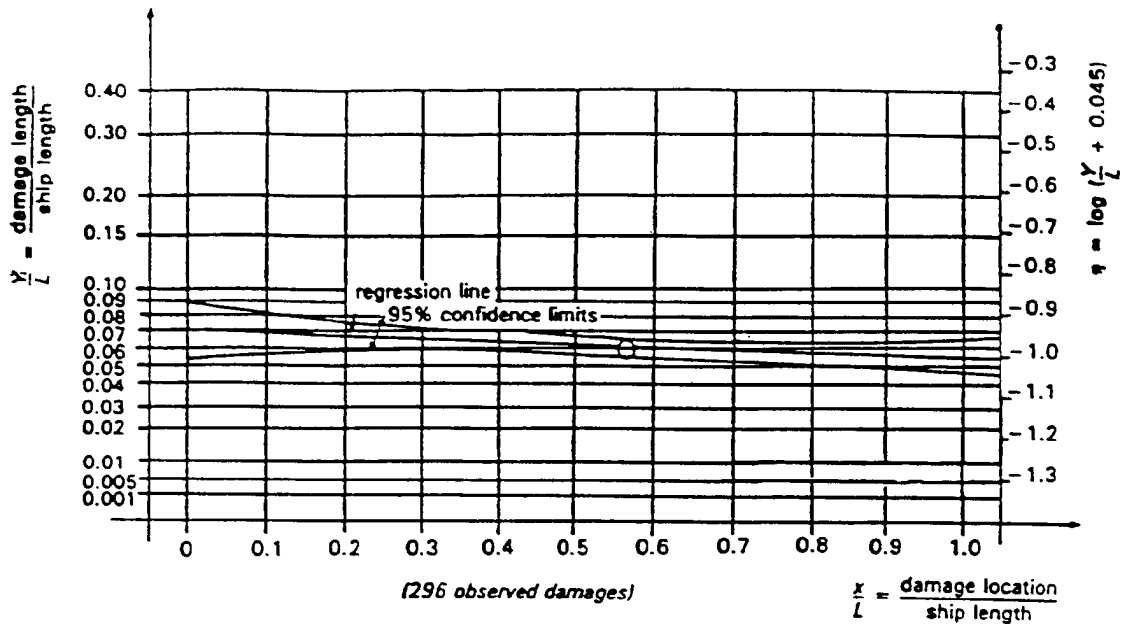

Figure 10 - Regression of nondimensional damage length on nondimensional damage location

### 3.4 Dependence of damage length on year of collision

The fact that the speed and size of ships has tended to increase during recent years suggests that the average size of damage in cases of collision is also growing. In order to investigate this, a regression analysis of the logarithm of the nondimensional damage length on the year of collision has been made. The result is shown in figure 11. This figure shows a significant positive slope of the regression line, which proves that, on average, the damage length increases with year of collision.

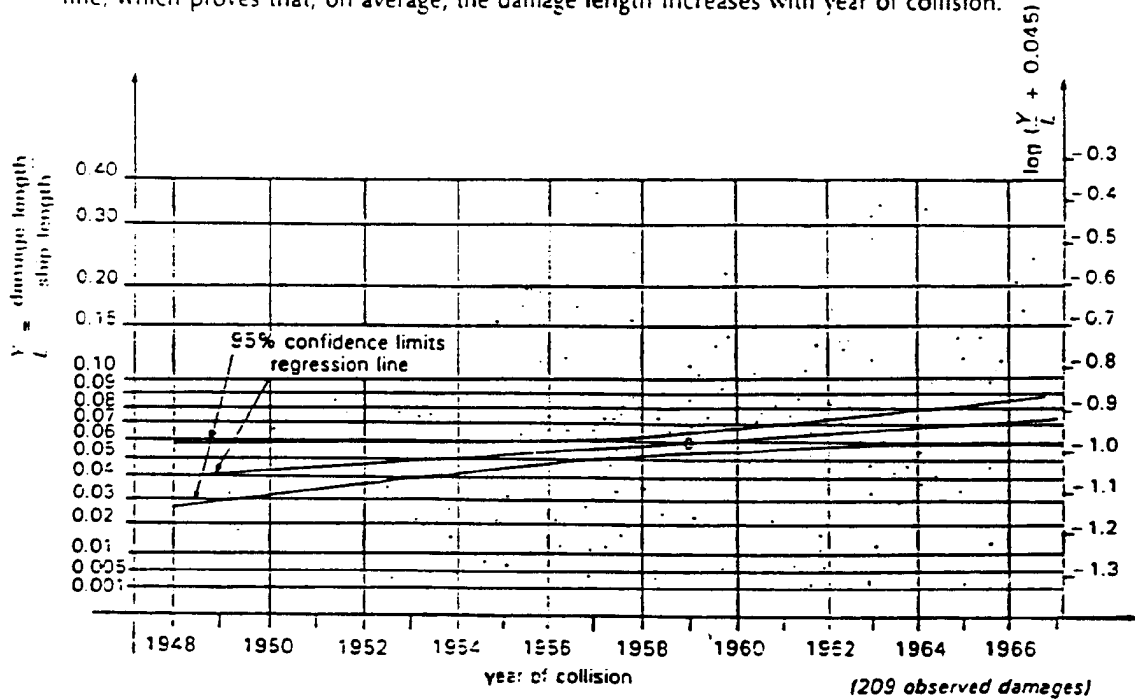

Figure 11 - Regression of nondimensional damage length depending on year of collision

It therefore seems prudent not to use the distribution which results from all damage data independent of the year of collision. Assuming that the variance about the regression line is constant, it is possible to derive from the regression analysis the distribution function of non-dimensional damage length for any arbitrarily chosen year; such a function is determined by the mean (which is given by the regression line) and the variance about the regression line of the logarithm of  $y/L + e_y$ . Some samples are given in figures 12 and 13.

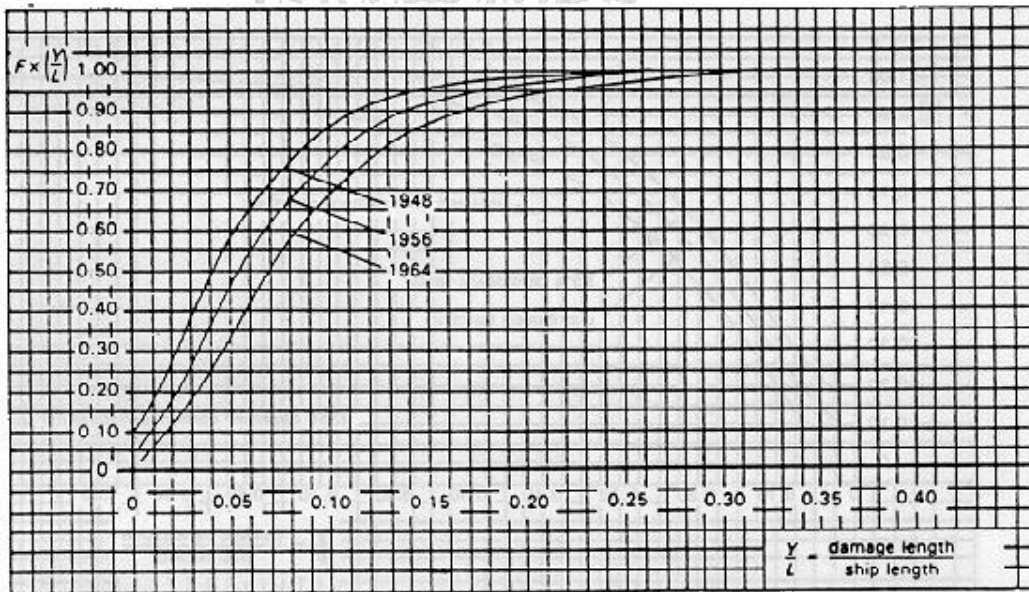

Figure 12 - Distribution function of nondimensional damage length for respective year of collision

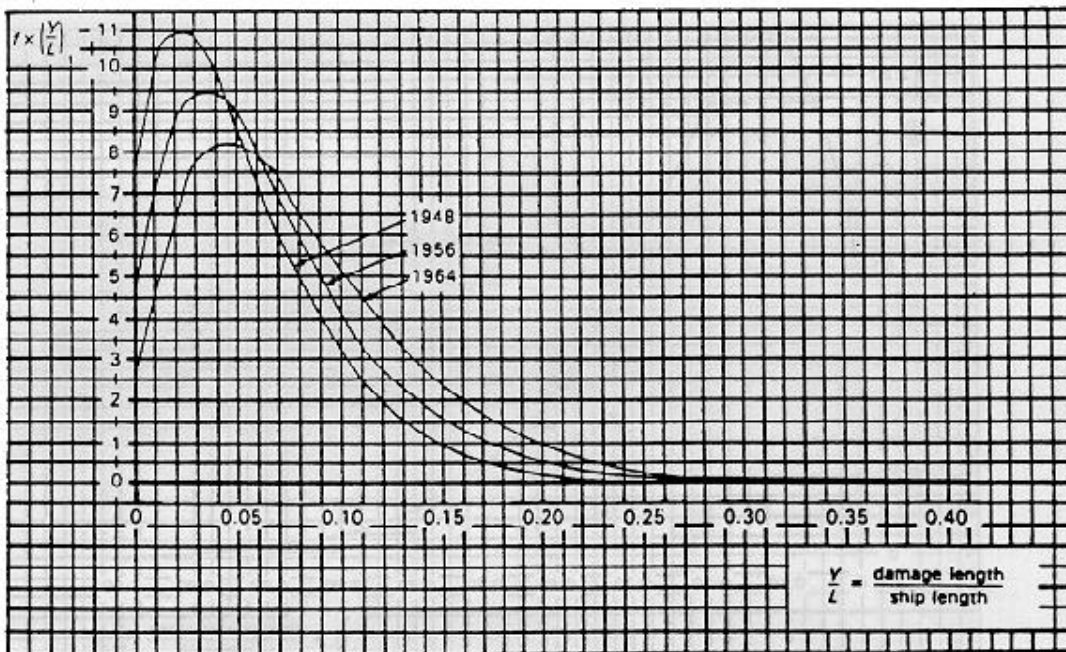

Figure 13 - Distribution density of nondimensional damage length for respective year of collision



Similar considerations as in the case of the damage length lead to the conclusion that  $z/B + e_z$  is approximately log-normally distributed and does not depend on the ship size, which in this connection is represented by the breadth  $B$  of the ship. Figures 14 and 15 show good agreement between the log-normal distribution and the corresponding values obtained from the damage statistics. Figure 16 proves that there is, in fact, no significant dependence of  $z/B$  on  $B$ .

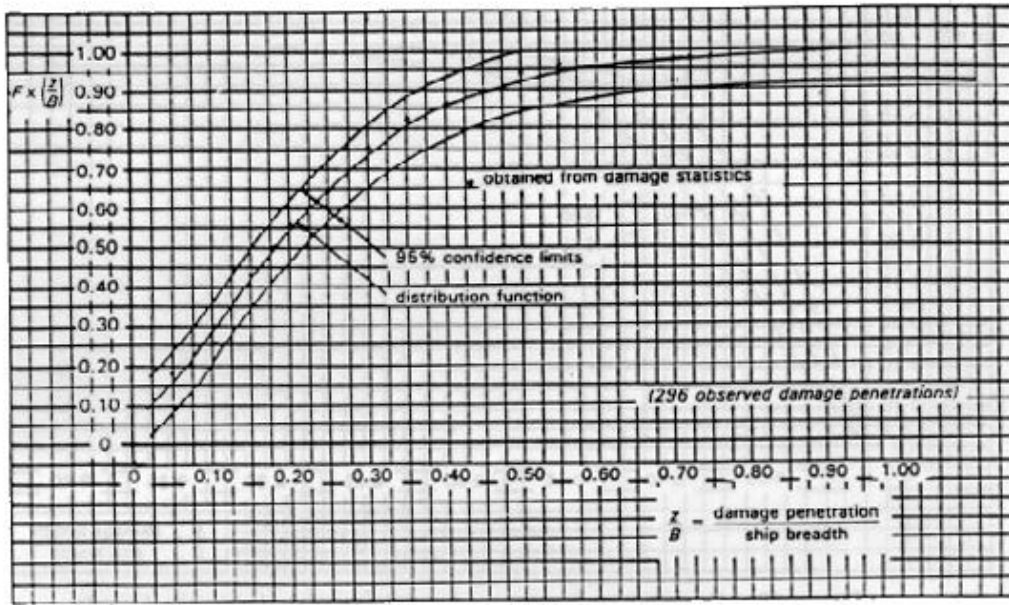

Figure 14 - Distribution function of nondimensional damage penetration

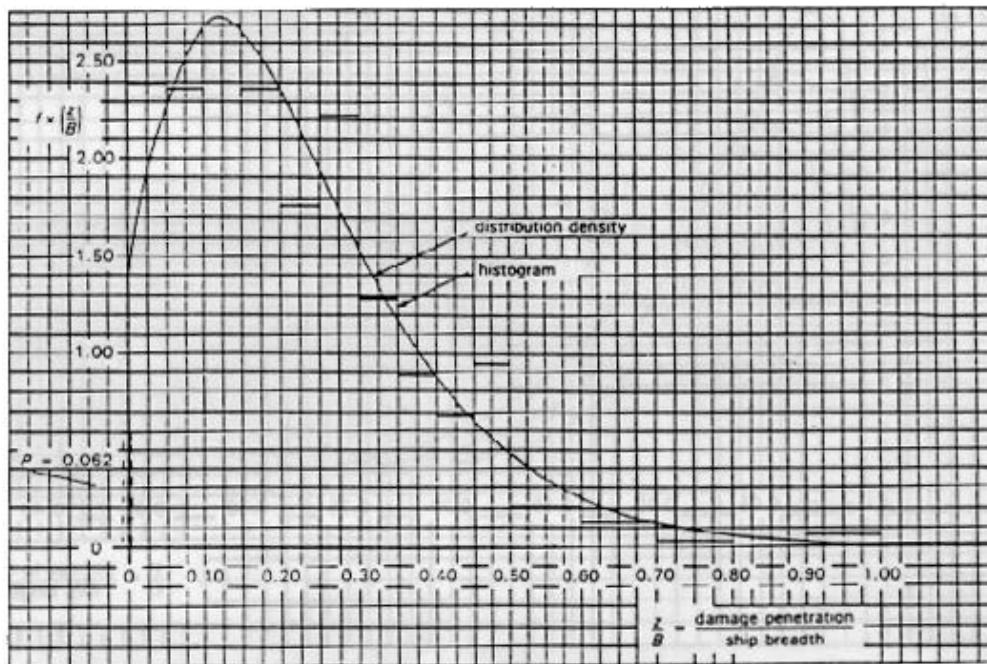

Figure 15 - Distribution density of nondimensional damage penetration

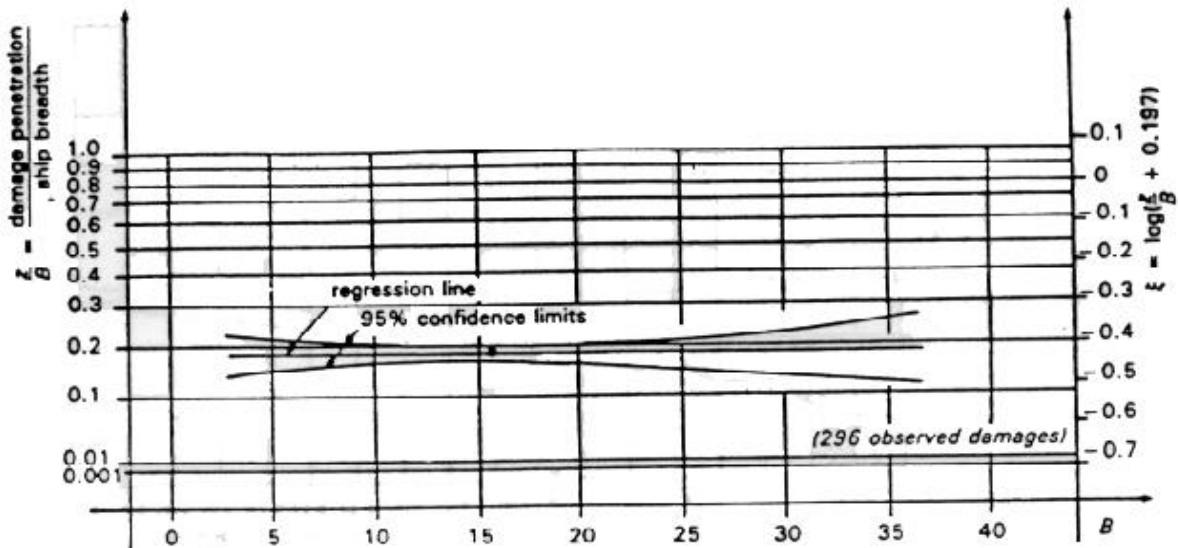

Figure 16 - Regression of nondimensional damage penetration on ship breadth

As is to be expected, there is a strong correlation between  $z/B$  and  $y/L$ . Figure 17 and 18 show that  $z/B$  increases on the average with increasing  $y/L$ . The joint distribution of the logarithm of  $(y/L + e_y)$  and  $(z/B + e_z)$  is a bivariate normal distribution. From that distribution the conditional distribution at  $z/B$ , on the condition that the damage length assumes certain values of  $y/L$ , can be derived.

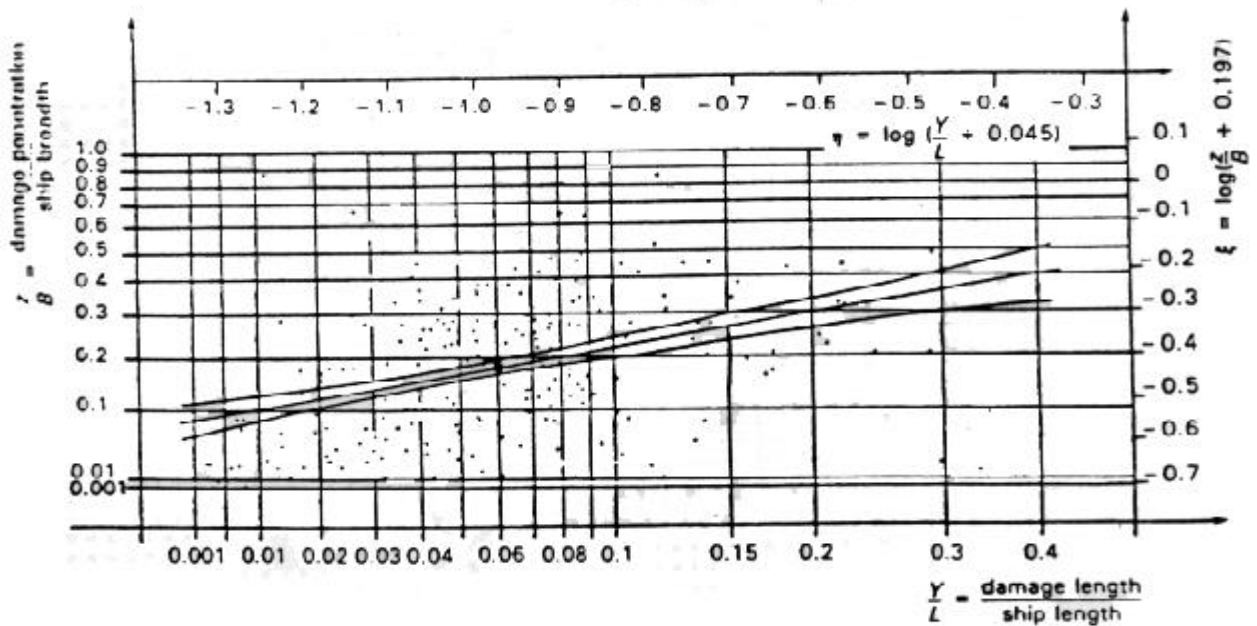

Figure 17

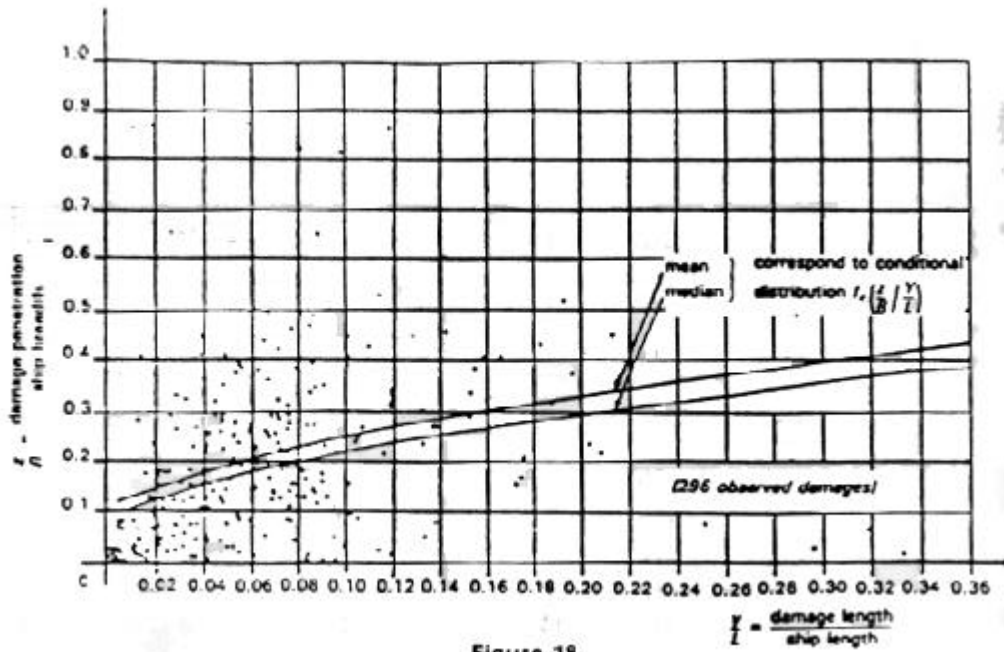

Figure 18

### 3.6 Distribution of damage location

Inspection of the histogram (figure 19) of the non-dimensional damage location shows that damages in the forward half to the ship are more frequent than in the aft part. The only explanation which can be offered for the peaks of the histogram at approximately  $x/L=0.45$  and  $x/L=0.95$  is that they are random because of the limited sample

Because the damage location is defined as distance from the aft terminal of  $L$  to the center of the damage, it is always at a distance of  $y/2L$  from the ends of the ship. Starting with a simple assumption for the conditional that  $y/L$  assumes certain values, the marginal distribution density has been derived and is shown as a curve in figure 19. The corresponding distribution function is given in figure 20.

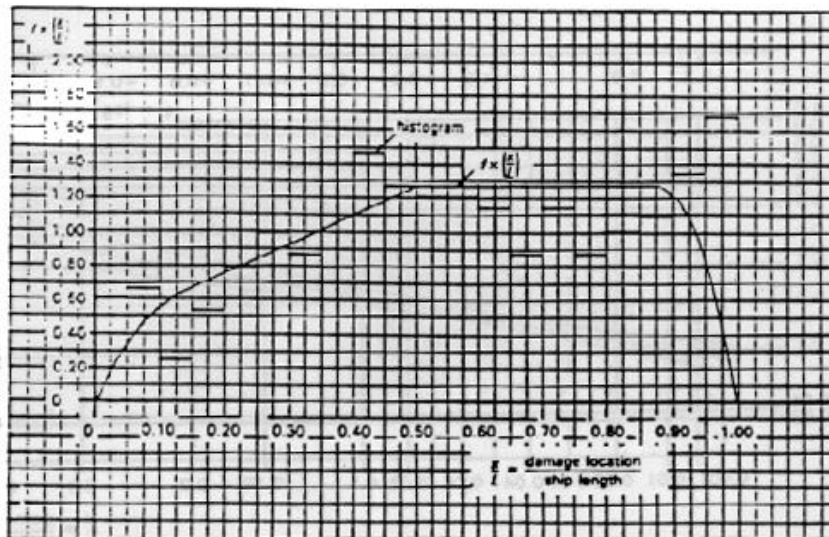

Figure 19 - Distribution density of nondimensional damage location

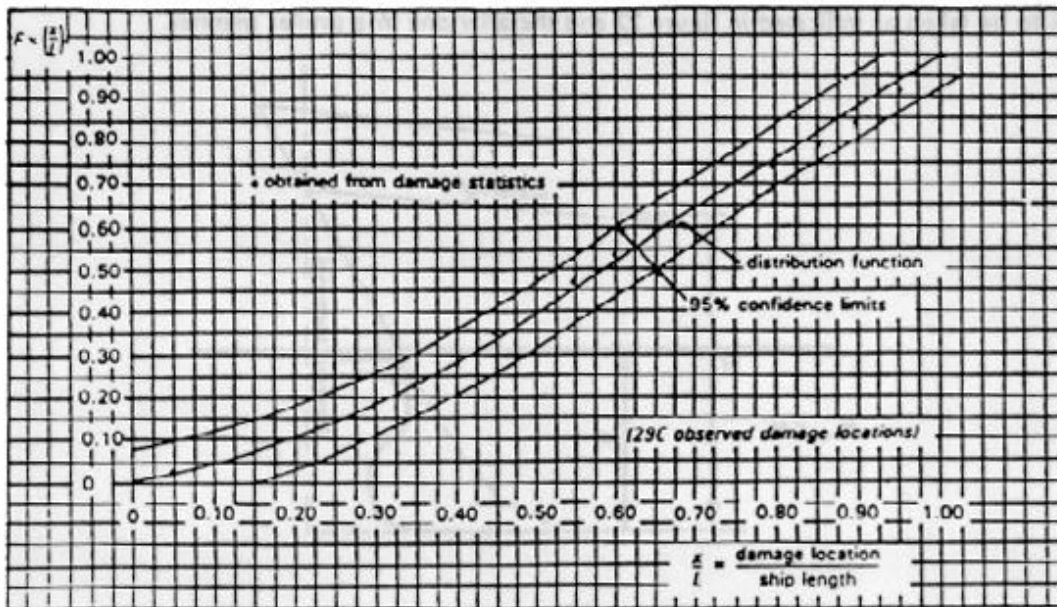

Figure 20 - Distribution function of nondimensional damage location

#### 4 PROBABILITY OF CAPSIZE

(Determination of the probability that a damaged ship will not capsize or sink -- calculation of the  $s_i$ -value)

##### 4.1 Criteria proposed to avoid capsizing or sinking

It is not possible with the present state of knowledge to determine, with any degree of accuracy, criteria related to the probability of capsize of ships in waves. Therefore the formulae contained in these regulations are simplified and based on common standards used for damaged stability calculations.

#### Part B

This part of the explanatory notes is intended give guidance on how to apply the individual regulations.

##### Regulation 25-1

The purpose of .6 of the footnote to regulation 25-1 is to exclude from the application of the regulations on subdivision and damage stability of cargo ships (part B-1) only those ships which must comply with the damage stability requirements of the 1M Load Line Convention in order to obtain a type A or type B-60 through to type B-100 freeboard assignment.

Part B-1 regulations were developed and intended as a separate required standard for all cargo ships. Equivalency between the part B-1 damage stability requirements and those of the Load Line Convention is neither implied nor suggested.

##### Paragraph 3

The circumstances where this paragraph of the regulations might apply include, for example, the following;

1. ships constructed in accordance with a standard of damage stability with a set of damage criteria agreed by the Administration;

For the forward deck limiting the vertical extent of flooding,  $H_{max}$ , is to be calculated in accordance with the draught ( $d_1$ ) at the deepest subdivision load line, based on the corresponding formula in regulation 25-6, paragraph 3.3. The forward terminal position at the deepest subdivision load line is to be taken as indicated in figure 22 and the after one in a similar manner.

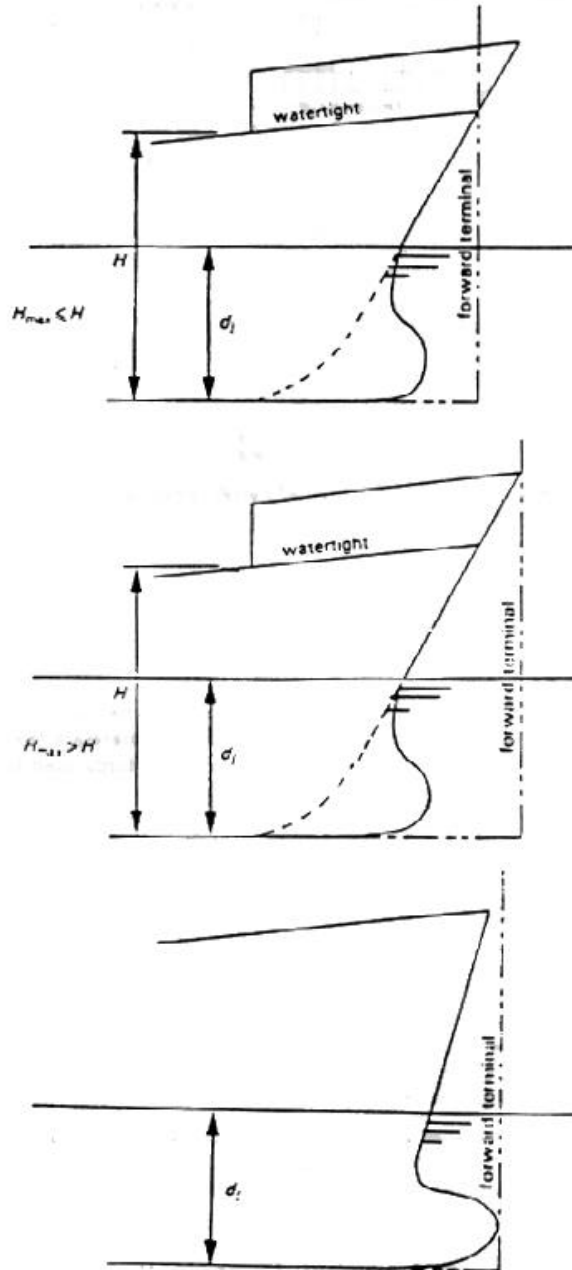

Figure 22

*Paragraph 1*

The regulations do not specify at which side of the ship damage should be assumed. Where there is 100% symmetry about the ship centerline of:

- the main hull,
- erections which are given credit for buoyancy in the damage stability calculations,
- the internal subdivision restricting the extent of flooding for the damage stability calculations,

it is dear that damage may be assumed on either the port or starboard sides, each producing the same value of A.

It is rare for complete symmetry to exist and therefore, in theory, two calculations for A should be made, one assuming port damage and the other starboard damage.

However, the calculated A value may be taken as that which evidently gives the less favorable result. Otherwise the mean value obtained from calculations involving both sides is to be used.

*Paragraph 2*

$$A = \sum p_i s_i$$

where:

$p_i$  is independent of the draught but includes the factor  $r$ ,

$s_i$  is dependent on the draught and includes the factor  $v$ , and is a weighted average of  $s$ -factors calculated at draughts of  $d_1$  and  $d_p$ .

It is recommended that the product  $p_i s_i$ , should be calculated using five decimal places, while the final results, i.e. the indices A and R, should be to at least three decimal places.

*Paragraph 3*

For any ship, including those with a raked keel, the design waterline should be used as a reference for level trim.

*Paragraph 6*

See figures in appendix 2.

When there is more than one longitudinal subdivision to consider, penetration need not extend to the ship's centerline if such penetration does not provide any contribution to the attained subdivision index.

For example, when a pipe tunnel in the center of a ship is fitted, damage to this tunnel may cause heavy progressive flooding leading to loss of the vessel. In this instance the penetration may be stopped outside the pipe tunnel, and the  $p$ -factor multiplied by the factor  $r$ , as calculated for a penetration in a wing compartment only. If a wing compartment is fitted in addition, it is possible to take account of two different penetrations, and applying the factor  $(r_2 - r_1)$  rather than  $(1 - r)$ , as obtained when the damage is extended to the centerline.

$r_2$  is then the  $r$ -value for penetration to the pipe tunnel only, and  $r_1$  is the  $r$ -value for penetration to the longitudinal bulkhead only. See figure A-11 (VHi) in appendix 3.

Regulation 25-5

See figures and explanations in appendices 2 and 3.

In particular, note when calculating r-values for a group of two or more adjacent compartment:(or zones) the b-value must be the same for all compartments (or zones) in that group.

Regulation 25-6

Paragraph 1.2

If the final waterline immerses the lower edge of any opening through which progressive flooding takes place, the factor s may be recalculated taking such flooding into account. If the resulting s is greater than zero, the  $dA$  of the compartment or group of compartments may contribute to the index A.

Paragraph 3.3

Where the height of a horizontal subdivision above the baseline is not constant, the height of the lowest point or' the horizontal subdivision above the baseline should be used in calculating H.

Regulation 25-8

Paragraph 1.1

It is straightforward to obtain minimum GM (or maximum KG) values which comply with the relevant intact stability requirements, and can be expressed by a unique curve against ship draught.

However, it is not possible to obtain a unique set of minimum GM values for deepest load draught( $d_1$ ) and for partially loaded draught ( $d_p$ ) which ensure compliance with regulations 25-1 to 25-6, because there are an infinite number of sets of GMs to meet the regulations.

Therefore, one approach might be to choose a GM value for the deepest loaded draught as close as possible to the minimum GM value relevant to the intact stability requirements based on a realistic loading condition, then vary the GM value for partial loaded draught while retaining a realistic loading condition and obtain a limiting value of GM to comply with regulations 25-1 to 25-6.

Of Course, other practical approaches may also be taken.

Paragraph 1.2

Where cross-flooding arrangements are fitted, calculations are to be carried out in accordance with IMO resolution A.266(VIII).

The time for equalization shall not exceed ten minutes.

Paragraph 3

Curves of limiting GMs should be drawn as indicated in figures 23 and 24.

Regulation 25-9

Paragraph 4

The words satisfactory and essential mean that scantlings and sealing requirements for those doors or ramps should be sufficient to withstand the maximum head of the water at the flooded waterline.

In figure (vfv)

$$dA = \rho_l \times \left\{ r_1 \times [v_1 \times s_{min11} + (1 - v_1) \times s_{min12}] \right. \\ \left. + (1 - r_1) \times [v_1 \times s_{min21} + (1 - v_1) \times s_{min22}] \right\}$$

where:

- $s_{min11}$  = the least of  $s_{1234}$  and  $s_{234}$  and  $s_{34}$  and  $s_4$
- $s_{min12}$  = the least of  $s_{12345}$  and  $s_{2345}$  and  $s_{345}$  and  $s_{45}$
- $s_{min21}$  = the least of  $s_{1234678}$  and  $s_{234678}$  and  $s_{3478}$  and  $s_{48}$
- $s_{min22}$  = the least of  $s_{123456789}$  and  $s_{23456789}$  and  $s_{3456789}$  and  $s_{4569}$

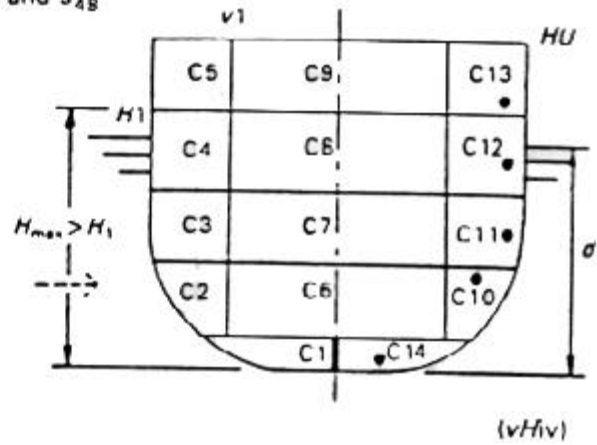

Figure A-12 - Interpretation of combined longitudinal and horizontal subdivision



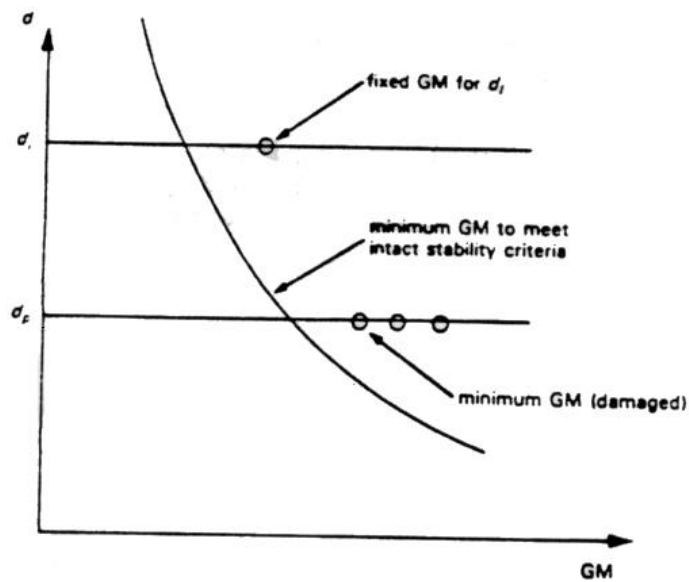

Figure 23

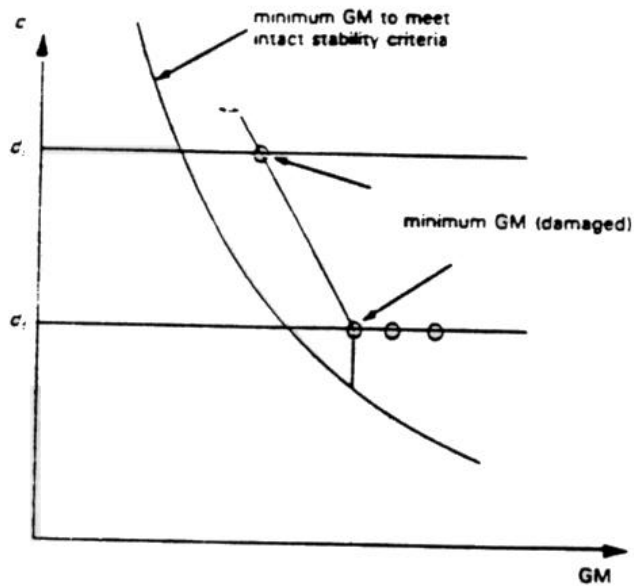

Figure 24

### Appendix 1 Transverse subdivision

This appendix illustrates, by means of examples, how to divide the ship length  $L_s$  into discrete damage tones. The subdivision of  $L_s$  into damage zones should not only take account of existing transverse bulkheads but also separate smaller local watertight compartments, the flooding of which has significant influence on the damage stability results.

1 Figure A-1 shows the elevation of a part of a ship containing two compartments named A and B. Compartment A is divided by local subdivision into the spaces A1 and A2. For the purpose of calculating the products  $p_s$  which contribute most favorably to the attained subdivision index, three fictitious compartments or damage zones are considered. The bases for calculations of the  $p$  and  $s$ -values are given below:

- .1 Zone 1 of length  $l_1$ :  $p$  based on  $l_1$   
 $s$  based on flooding of space  $A_1$
- .2 Zone 2 of length  $l_2$ :  $p$  based on  $l_2$   
 $s$  based on flooding of space  $A_1$  only or of  $A_2$  only, or  $A_1$  and  $A_2$ , whichever results in the least  $s$ -value
- .3 Zone 3 (or space B) of length  $l_3$ :  $p$  based on  $l_3$   
 $s$  based on flooding of space B
- .4 Zone 1 + 2:  $p$  based on  $l_1$  and  $l_2$   
 $s$  based on flooding of  $A_1$  or of  $A_1$  and  $A_2$ , whichever results in the lesser  $s$ -value
- .5 Zone 2 + 3:  $p$  based on  $l_2$  and  $l_3$   
 $s$  based on flooding of  $A_1$  and  $A_2$  and B or of  $A_1$  and B or of  $A_2$  and B, whichever results in the lesser  $s$ -value

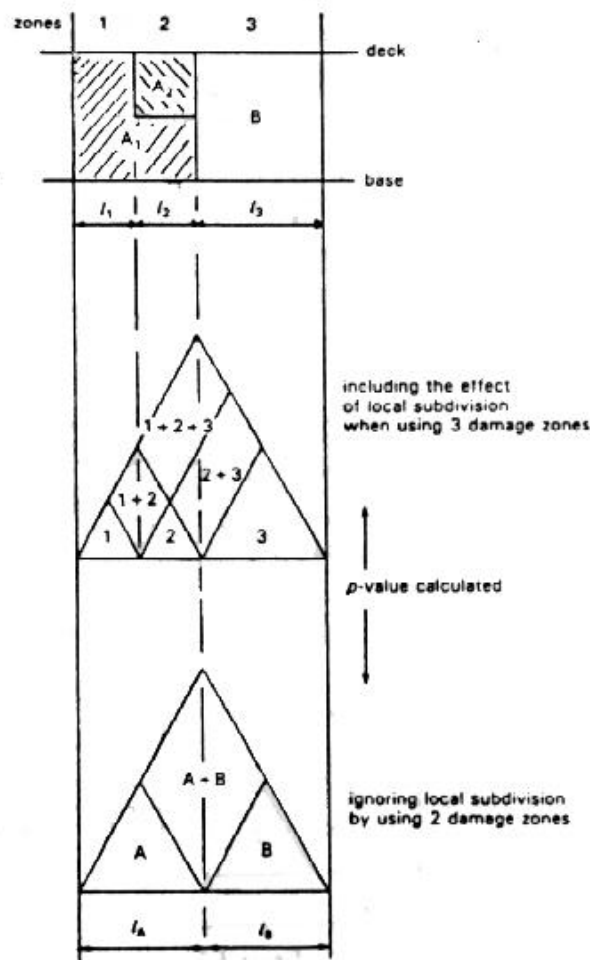

Figure A-1

.6 Zones 1 + 2 + 3

p based on  $l_a$   
s based on flooding of  $A_1$  and B or of  $A_1$  and  $A_2$  and B whichever results in the lesser s-value

2 It would also be compatible with the regulations to ignore the local subdivision with respect to the calculation of the p-value. In this case, the following compartments and group of compartments would be considered:

.1 Zone a of length  $l_3 = l_1 + l_2$ : p based on  $l_a$

.2 Zone b of length  $l_b (=l_3)$ : p based on  $l_b$   
s based on flooding of space B

.3 Zones a + b:  
p based on  $l_a$  and  $l_b$   
s based on flooding of  $A_1$  and B or of  $A_2$  and B or of  $A_1$  and  $A_2$  and B, whichever results in the least s-value

3 Obviously, the approach given in paragraph 1 above will generally lead to an attained sub-division index which is higher than (or at least equal to) that defined by the approach of paragraph 2. Also, the error made by neglecting the actual distribution of damage in the vertical direction is much smaller in the first case.

Another example of local subdivision is shown in figure A-2. The following tables illustrate how this can be handled.

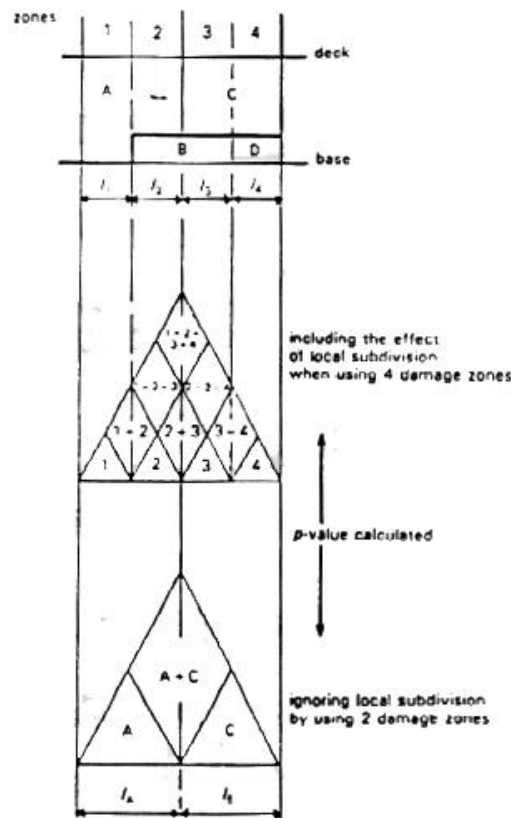

Figure A-2

Table A-1 - p-value calculated including the effect of local subdivision

Damage zones measuring length of space opened	phased an length(s)	S based on the flooding of space(s) resulting in the poorest stability
1	$l_1$	space A
2	$l_2$	space A or space B or spaces A and B*
3	$l_3$	space B or space C or spaces B and C*
4	$l_4$	space C or space D or spaces C and D*
1+2	$l_1, l_2$	space A or spaces A and B*
2+3	$l_2, l_3$	space B or spaces A and C or spaces A, B and C*
3+4	$l_3, l_4$	space C or spaces B and D or spaces B and C and D*
1+2+3	$l_1, l_2, l_3$	spaces A and B or A and C or A and B and C*
2+3+4	$l_2, l_3, l_4$	spaces A and C or B and D or A and B and C and D*
1+2+3+4	$l_1, l_2, l_3, l_4$	spaces A and C or A and B and D or A and B and C and D*

\*= whichever results in a smaller s-value

Table A-2 - p-value calculated ignoring local subdivision

Damage zones measuring length of space opened	p based on length(s)	S based on the flooding of space(s) resulting in the poorest stability
A	$l_A = l_1 + l_2$	Space A or space B or spaces A and B*
C	$l_C = l_3 + l_4$	Space C or space B or space D or space C and B or spaces B and D or spaces C and D or spaces B and C and D*
A+C	$l_A, l_C$	Space B or spaces A and C or spaces B and D or spaces A and B and C or spaces A and B and D or spaces A and B and C and D*

\*= whichever results in a smaller s-value

## 1 Combined transverse, horizontal and longitudinal subdivision

1 Provision has been included in the new regulations to permit evaluation and acceptance of ships with combined longitudinal and transverse subdivision. To facilitate a full understanding and correct and uniform application of the new provisions, some illustrative material is contained in this appendix. The examples given are based on three different arrangements of combined longitudinal and transverse subdivision as shown in figures A-3, A-4 and A-5.

2 The following nomenclature is used in this section:

$l_1, l_2, l_3$ , etc. distance between bulkheads bounding either inboard or wing compartments as shown in figures A-3, A-4 and A-5;

$l_{12}=l_1+l_2; l_{23}=l_2+l_3; l_{34}=l_3+l_4$ , etc.

$l_{1-3}=l_1+l_2+l_3; l_{2-4}=l_2+l_3+l_4$

$l_{2-5}=l_2+l_3+l_4+l_5; l_{3-6}=l_3+l_4+l_5+l_6$ , etc.;

$p_1, p_2, p_3$ , etc. are p calculated according to regulation 25-5.1 using  $l_1, l_2, l_3$ , etc. as l;

$p_{12}, p_{23}, p_{34}$ , etc. are p calculated according to regulation 25-5.1 using  $l_{12}, l_{23}, l_{34}$ , etc. as l;

$p_{1-3}, p_{2-4}$ , etc. are p calculated according to regulation 25-5.1 using  $l_{1-3}, l_{2-4}$ , etc. as l;

$p_{2-5}, p_{3-6}$ , etc. are p calculated according to regulation 25-5.1 using  $l_{2-5}, l_{3-6}$ , etc. as l;

$r_1, r_2, r_3$ , etc. are r calculated according to regulation 25-5.2 using  $l_1, l_2, l_3$ , etc. as l, and b as defined in regulation 25-5.2;

$r_{12}, r_{23}, r_{34}$ , etc. are r calculated according to regulation 25-5.2 using  $l_{12}, l_{23}, l_{34}$ , etc. as l, and b as defined in regulation 25-5.2;

$r_{2-5}, r_{3-6}$ , etc. are r calculated according to regulation 25-5.2 using  $l_{2-5}, l_{3-6}$ , etc. as l, and b as defined in regulation 25-5.2;

b as defined in regulation 25-5.2

In calculating r-values for a group of two or more adjacent compartments, the b-value is common for all compartments in that group, and equal to the smallest b-value in that group:

$$b = \min \{b_1, b_2 \dots b_n\}$$

where:

n = number of wing compartments in that group;

$b_1, b_2 \dots b_n$  are the mean values of b for individual wing compartments contained in the group.

When determining the factor p for simultaneous flooding of space 1 (in figures A-4 and A-5) and adjacent side compartment(s) the values  $r_1, r_{12}$ , etc., should be calculated according to regulation 25-5.2, taking b for space 1 equal to the breadth of the adjacent side compartment(s).

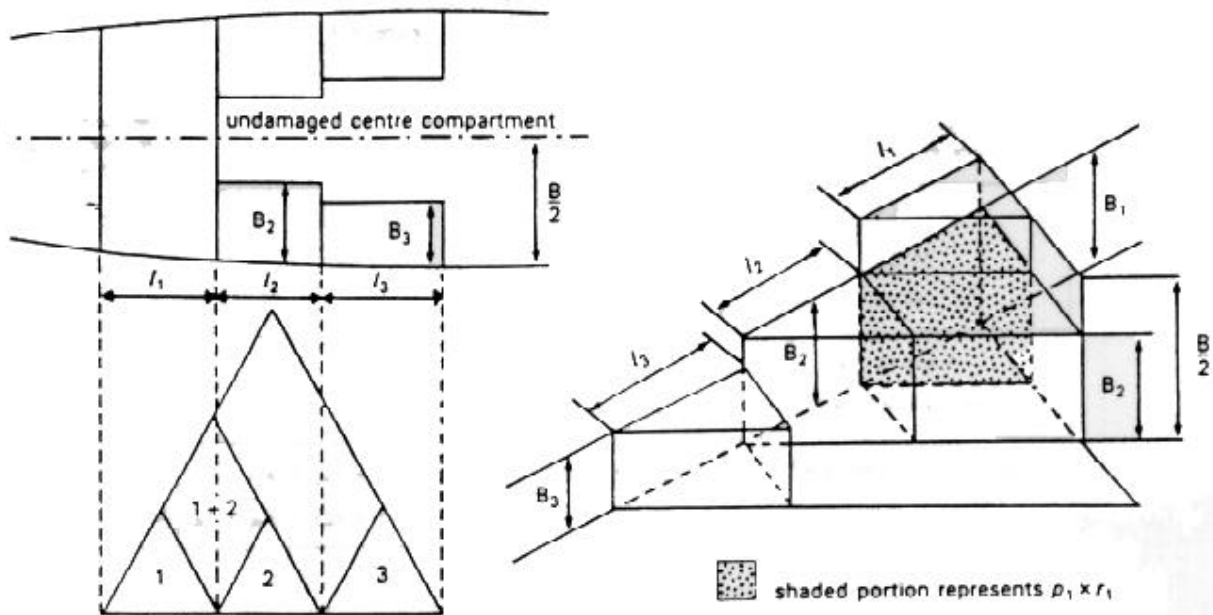

The  $p$ -factor for compartments 1+2:  $p = p_{12} \times r_{12} - p_1 \times r_1 - p_2 \times r_2$

where:  $r_1$  is a function of  $l_1$  and  $b_2$

$r_2$  is a function of  $l_2$  and  $b_2$

$r_{12}$  is a function of  $l_1 = l_2$  and  $b_2$

Figure A-3 - Illustration of combined damage at the end of undamaged centre compartment

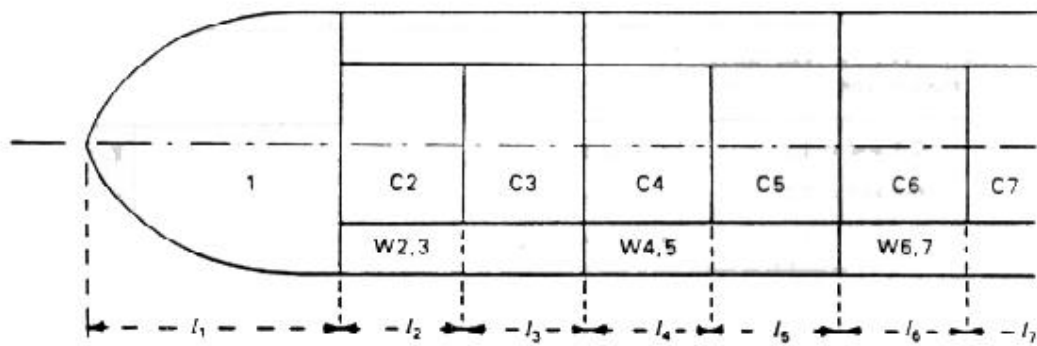

Figure A-4

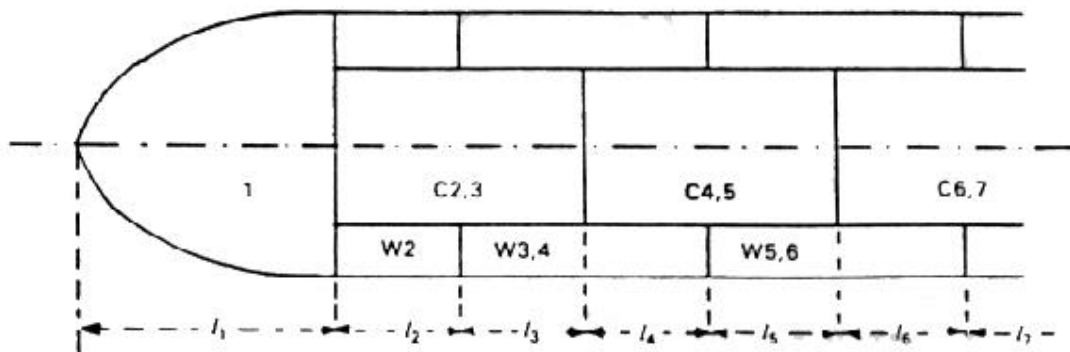

Figure A-5

Table A-3 - Application of regulation 25-5\* to subdivision arrangement shown in figure A-4

Damage zone(s) as compartment or group of compartments**	p-factor	Distances $X_1$ and $X_2$ for determination of factor p
1	$p = p_1$	$X_1 = 0 \quad X_2 = l_1$
W 2,3	$p = p_{23} \times r_{23}$	$X_1 = l_1 \quad X_2 = l_{1,3}$
W 4,5	$p = p_{45} \times r_{45}$	$X_1 = l_{1,3} \quad X_2 = l_{1,5}$
1 and W 2,3	$p = p_{1,3} \times r_{1,3} - p_1 \times r_1 - p_{23} \times r_{23}$	$X_1 = 0 \quad X_2 = l_{1,3}$
W 2,3 and W 4,5	$p = p_{2,5} \times r_{2,5} - p_{23} \times r_{23} - p_{45} \times r_{45}$	$X_1 = l_1 \quad X_2 = l_{1,5}$
2 and W 2,3 and W 4,5	$p = p_{1,5} \times r_{1,5} - p_{1,3} \times r_{1,3} - p_{2,5} \times r_{2,5} + p_{23} \times r_{23}$	$X_1 = 0 \quad X_2 = l_{1,5}$
W 2,3 and W 4,5 and W 6,7	$p = p_{2,7} \times r_{2,7} - p_{2,5} \times r_{2,5} - p_{4,7} \times r_{4,7} + p_{45} \times r_{45}$	$X_1 = l_1 \quad X_2 = l_{1,7}$

$r_{1,3}$  is a function of  $l_{1,3}$  and  $b_{2,3}$ .

$r_{45}$  is a function of  $l_{45}$  and  $b_{2,7}$ .

Table A-4 - Application of regulation 25-5\* to subdivision arrangement shown in figure A-4

Damage zone(s) as compartment or group of compartments**	p-factor	Distances $X_1$ and $X_2$ for determination of factor p
C 2 and W 2,3	$p = p_2 \times (1 - r_2)$	$X_1 = l_1 \quad X_2 = l_{12}$
C 3 and W 2,3	$p = p_3 \times (1 - r_3)$	$X_1 = l_{12} \quad X_2 = l_{1,3}$
C 4 and W 4,5	$p = p_4 \times (1 - r_4)$	$X_1 = l_{1,3} \quad X_2 = l_{1,4}$
1 and C 2 and W 2,3	$p = p_{12}(1 - r_{12}) - p_1(1 - r_1) - p_2(1 - r_2)$	$X_1 = 0 \quad X_2 = l_{12}$
C 2 and C 3 and W 2,3	$p = p_{23}(1 - r_{23}) - p_2(1 - r_2) - p_3(1 - r_3)$	$X_1 = l_1 \quad X_2 = l_{1,3}$
C 3 and C 4 and W 2,3 and W 4,5	$p = p_{34}(1 - r_{34}) - p_3(1 - r_3) - p_4(1 - r_4)$	$X_1 = l_{12} \quad X_2 = l_{1,4}$
1 and C 2 and C 3 and W 2,3	$p = p_{1,3}(1 - r_{1,3}) - p_{12}(1 - r_{12}) - p_{23}(1 - r_{23}) + p_2(1 - r_2)$	$X_1 = 0 \quad X_2 = l_{1,3}$
C 2 and C 3 and C 4 and W 2,3 and W 4,5	$p = p_{2,4}(1 - r_{2,4}) - p_{23}(1 - r_{23}) - p_{34}(1 - r_{34}) + p_2(1 - r_2)$	$X_1 = l_1 \quad X_2 = l_{1,4}$

\* With particular reference to regulation 25-5.1 and 25-5.2.1

\*\* To be considered flooded for s-calculation.

Table A-5 - Application of regulation 25-5\* to subdivision arrangement shown in figure A-5

Damage zone(s) as compartment or group of compartments**	p-factor	Distances $X_1$ and $X_2$ for determination of factor p
1	$p = p_1$	$X_1 = 0$ $X_2 = l_1$
W 2	$p = p_2 \times r_2$	$X_1 = l_1$ $X_2 = l_{12}$
W 3,4	$p = p_{34} \times r_{34}$	$X_1 = l_{12}$ $X_2 = l_{1-4}$
1 and W 2	$p = p_{12} \times r_{12} - p_1 \times r_1 - p_2 \times r_2$	$X_1 = 0$ $X_2 = l_{12}$
W 2 and W 3,4	$p = p_{2-4} \times r_{2-4} - p_2 \times r_2 - p_{34} \times r_{34}$	$X_1 = l_1$ $X_2 = l_{1-4}$
1 and W 2 and W 3,4	$p = p_{1-4} \times r_{1-4} - p_{12} \times r_{12} - p_{2-4} \times r_{2-4} + p_2 \times r_2$	$X_1 = 0$ $X_2 = l_{1-4}$
W 2 and W 3,4 and W 5,6	$p = p_{2-4} \times r_{2-4} - p_{2-4} - r_{2-4} - p_{34} \times r_{34} + p_{34} \times r_{34}$	$X_1 = l_1$ $X_2 = l_{1-4}$

Table A-6 - Application of regulation 25-5\* to subdivision arrangement shown in figure A-5

Damage zone(s) as compartment or group of compartments**	p-factor	Distances $X_1$ and $X_2$ for determination of factor p
C 2,3 and W 2	$p = p_2(1-r_2)$	$X_1 = l_1$ $X_2 = l_{12}$
C 2,3 and W 3,4	$p = p_3(1-r_3)$	$X_1 = l_{12}$ $X_2 = l_{1-3}$
C 4,5 and W 3,4	$p = p_4(1-r_4)$	$X_1 = l_{1-3}$ $X_2 = l_{1-4}$
1 and C 2,3 and W 2	$p = p_{12}(1-r_{12}) - p_1(1-r_1) - p_2(1-r_2)$	$X_1 = 0$ $X_2 = l_{12}$
1 and C 2,3 and W 2 and W 3,4	$p = p_{1-3}(1-r_{1-3}) - p_{12}(1-r_{12}) - p_{23}(1-r_{23}) + p_2(1-r_2)$	$X_1 = 0$ $X_2 = l_{1-3}$
C 2,3 and C 4,5 and W 3,4	$p = p_{34}(1-r_{34})$	$X_1 = l_{12}$ $X_2 = l_{1-4}$
C 2,3 and C 4,5 and W 2 and W 3,4	$p = p_{24}(1-r_{24}) - p_2(1-r_2) - p_{34}(1-r_{34})$	$X_1 = l_1$ $X_2 = l_{1-4}$
C 2,3 and C 4,5 and W 3,4 and W 5,6	$p = p_{35}(1-r_{35}) - p_{34}(1-r_{34}) - p_5(1-r_5)$	$X_1 = l_{12}$ $X_2 = l_{1-5}$
C 2,3 and C 4,5 and W 2 and W 3,4 and W 5,6	$p = p_{25}(1-r_{25}) - p_{24}(1-r_{24}) - p_{35}(1-r_{35}) + p_{34}(1-r_{34})$	$X_1 = l_1$ $X_2 = l_{1-5}$

\* With particular reference to regulations 25-5.1 and 25-5.2.1.

\*\* To be considered flooded for s-calculation.



## II Recesses

1 Recesses may be treated as actual or fictitious compartments using the example in figure A-6.

2 The following nomenclature is used in this section:

- |  |  |
|--|--|
| <p><math>l_1, l_2, l_3</math><br/> <math>p_1, p_2, p_3</math><br/> <math>p_{12}, p_{23}</math><br/> <math>p_{123}</math><br/> <math>r_1</math><br/> <math>r_2</math><br/> <math>r_{12} \ r_{23}</math><br/> <math>r_{123}</math></p> | <p>length of damage zones as shown in figure A-6;<br/>         are <math>p</math> calculated according to regulation 25-5.1, using <math>l_1, l_2, l_3</math> as <math>l</math>;<br/>         are <math>p</math> calculated according to regulation 25-5.1, using <math>l_1 + l_2</math> and <math>l_2 + l_3</math>, as <math>l</math>;<br/>         is <math>p</math> calculated according to regulation 25-5.1, using <math>l_1 + l_2 + l_3</math> as <math>l</math>;<br/>         is <math>r</math> calculated according to regulation 25-5.2, using <math>l_1</math> as <math>l</math> and <math>b</math> as shown in figure A-6;<br/>         is <math>r</math> calculated according to regulation 25-5.2, using <math>l_2</math> as <math>l</math> and <math>b</math> as shown in figure A-6;<br/>         are <math>r</math> calculated according to regulation 25-5.2, using <math>l_1 + l_2</math> as <math>l</math> and <math>b</math> as shown in figure A-6;<br/>         is <math>r</math> calculated according to regulation 25-5.2, using <math>l_1 + l_2 + l_3</math> as <math>l</math> and <math>b</math> as shown in figure A-6;</p> |
|--|--|

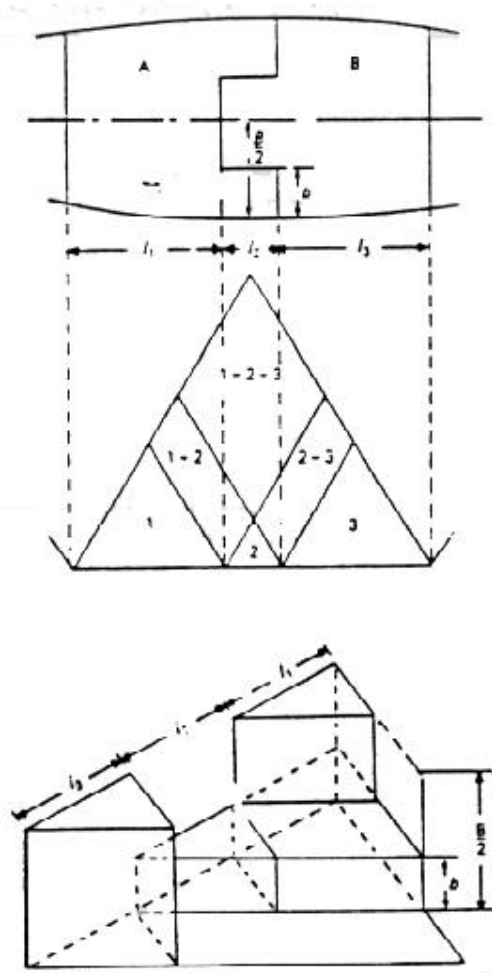

Figure A-6

3. Application to actual compartments:

Spaces to be considered flooded for s-calculation	p-factor to be used for calculating contribution to attained subdivision index
A	$p = p_{12} \times r_{12}$
B	$p = p_3$
A and B	$p = p_{123} - p_{12} \times r_{12} - p_3$

alternatively:

A	$p = p_1$
B	$p = p_3$
A and B	$p = p_{123} - p_1 - p_3$

4. Application to fictitious compartments:

A	$p = p_{12} \times r_{12} + p_1(1 - r_1)$
B	$p = p_3$
A and B	$p = p_{123} - p_{12} \times r_{12} - p_1(1 - r_1) - p_3$

### III Damage penetration

For uniform application of these regulations, the depth of penetration b should be determined using the following guidelines:

The mean transverse distance b shall be measured between the shell at the deepest subdivision load line and a vertical plane tangent to, or common with, all or a part of the longitudinal bulkhead but elsewhere outside thereof, and oriented so that this mean transverse distance to the shell is a maximum, except that in no case shall the maximum distance between this plane and the shell exceed twice the least distance between the plane and the shell. When the longitudinal bulkhead terminates below the deepest subdivision load line, the vertical plane referred to above is assumed to extend upwards to the deepest subdivision load line.

Figures A-7 and A-8 illustrate the application of this definition:

A damage zone containing abrupt changes of breadth may also be dealt with by subdividing into smaller zones, each having constant b-values.

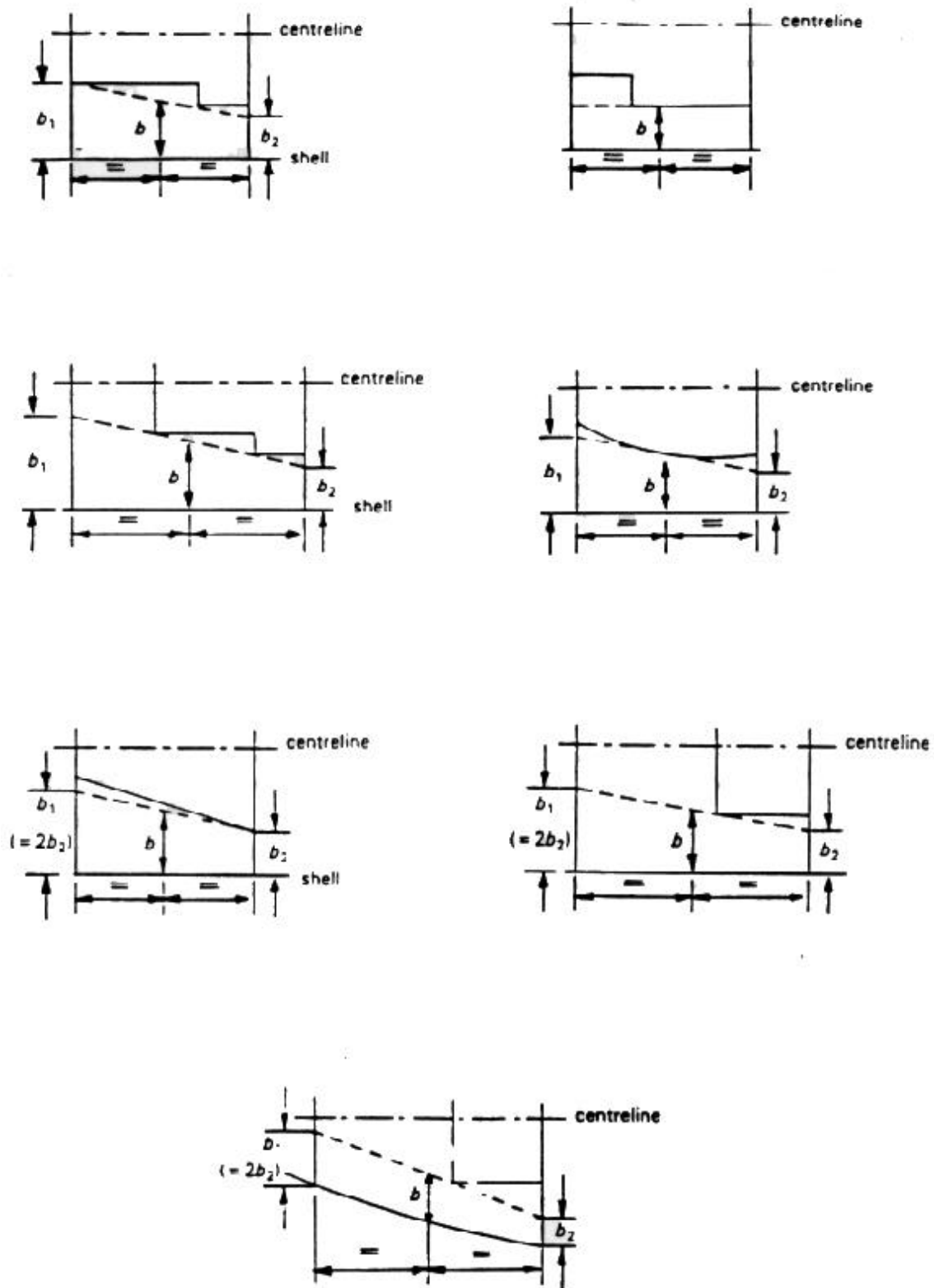

Figure A-7

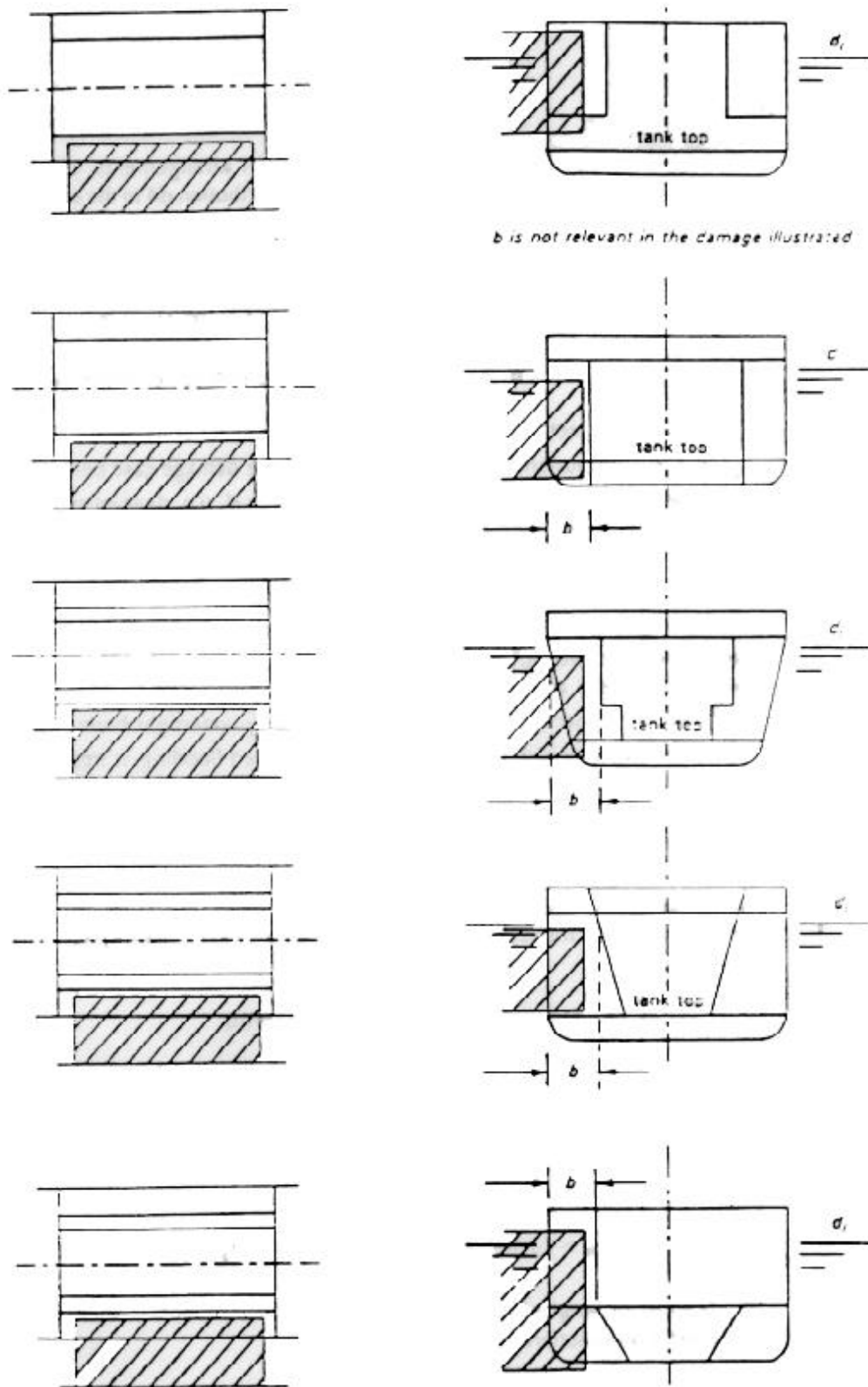

Figure A-8

### Appendix 3

#### 1 Introduction

This appendix describes various possible watertight subdivision arrangements, the consequent flooding scenarios and the method of determining the relevant contribution  $dA$  to the attained index  $A$ .

#### 2 Definition of the terms and symbols used

Note: Subscripts 1,2,3 etc., below relate to the appropriate spaces in figures A-9 to A-12. For example:

$C_{123}$  is a space comprising compartments  $C_1 C_2 C_3$ ;

$C_{345}$  is a space comprising compartments  $C_3 C_4 C_5$ ;

$C_{67}$  is the factor which accounts for the probability of survival after flooding compartments  $C_6 C_7$ , etc.



$dA$

Indicates the direction of the assumed side damage gives- the contribution to the attained index of the damage case being considered.

$d$

is the draught being considered and is either  $d_1$ , or  $d_p$  (i.e. deepest subdivision load line or partial load line).

$H_1, H_2$

are the first and second horizontal subdivisions, respectively, viewed from the waterline upwards.

$HU$

is the uppermost boundary which limits the vertical extent of flooding.

$v_1, v_2$

are the first and second longitudinal subdivisions, respectively, viewed from the side where damage is assumed.

$C$

indicates a compartment bounded on all sides by watertight boundaries.

$C_{123}$

indicates a space which, for the purpose of assumed flooding, is treated as a single space comprising compartments  $C_1, C_2$  and  $C_3$ .

•

indicates a compartment which lies outside the limits prescribed for all the damage scenarios: (ie the compartment remains intact for all assumed damage cases) except for possible cross-flooding.

$P$ ; ( regulation 25-5.1) is the factor which accounts for the probability that

the longitudinal extent of damage does not exceed the length of the damage zone (length  $l$ ) being considered.

#### 3. Contribution to the attained index $A$ applying various forms of watertight subdivision

This section details the contribution to the attained index  $A$  of various combinations of longitudinal and horizontal watertight subdivision, and illustrates the concept of multiple horizontal and longitudinal subdivision.

For multiple longitudinal subdivisions with no horizontal subdivisions, the general formula is:

$$dA = p_1 \times [r_1 \times s_1 + (r_2 - r_1) \times s_2 + \dots - (1 - r_{m-1}) \times s_m]$$

where:

$m$  = the number of longitudinal subdivisions, plus 1,

$r_1$  = the  $r$ -value as function of  $s$

$s_1$  = the  $s$ -factor for compartment  $i$

For multiple horizontal subdivisions, with no longitudinal subdivisions the general formula is:

$$dA = p_1 \times [v_1 \times s_{\min 1} + (v_2 - v_1) \times s_{\min 2} + \dots + (1 - v_{n-1}) \times s_{\min n}]$$

where:

- $n$  = the number of horizontal subdivisions between the subdivision waterline and  $H_{\max}$ , plus 1,
- $v_j$  = the  $v$ -value as function of assumed damage height  $H_j$ ,
- $s_{\min j}$  = the least  $s$ -factor for all combinations of damages obtained when the assumed damage extends from the assumed damage height  $H_j$  downwards

Generally, when there are combinations of longitudinal and horizontal subdivisions:

$$dA = p_1 \times [r_1 \times [v_1 s_{\min 11} + (v_2 - v_1) \times s_{\min 12} + \dots + (1 - v_{n-1}) \times s_{\min 1n}] + (r_2 - r_1) \times [v_1 s_{\min 21} + (v_2 - v_1) \times s_{\min 22} + \dots + (1 - v_{n-1}) \times s_{\min 2n}] + \dots + (1 - r_{m-1}) \times [v_1 \times s_{\min m1} + (v_2 - v_1) \times s_{\min m2} + \dots + (1 - v_{n-1}) \times s_{\min mn}]$$

where:

- $m$  = the number of longitudinal subdivisions, plus 1,
- $n$  = the number of horizontal subdivisions (within each longitudinal subdivision) between the subdivision waterline and  $H_{\max}$ , plus 1,
- $r_j$  = the  $r$ -factor as function of  $b_j$ ,
- $v_j$  = the  $v$ -value as function of assumed damage height  $H_j$ ,
- $s_{\min ij}$  = the least  $s$ -factor for all combinations of damages obtained when the assumed damage extends from the shell to  $b_j$  and from the assumed damage height  $H_j$  downwards.

The following examples illustrate how to deal with situations where there are combinations of longitudinal and horizontal subdivision, assuming the damage to occur between two consecutive watertight bulkheads only.

If, however, the damage extends beyond one or more transverse bulkheads, then all terms  $p_i$ ,  $r_i$  for  $i = 1, 2 \dots m$  are calculated for a group of wing compartments as a function of  $b_r$

### 3.1 Examples of longitudinal subdivision

Examples of longitudinal subdivision only are given in figure A-9.

Each part of the figure illustrates the damage cases which would need to be evaluated for a particular arrangement of watertight boundaries.

The formulae for calculating the contribution to the attained index  $dA$  are given in each case.

### 3.2 Examples of horizontal subdivision

Examples of horizontal subdivision only are given in figure A-10.

This illustrates the principles described in the previous section as applied to horizontal subdivision.

Regulation 25-4.7 specifies that, in the event that a lesser vertical extent of damage means a lesser contribution to the  $A$ -value, then this lesser extent is to be assumed in obtaining the requisite damage stability results.

### 3.3 Examples of longitudinal/horizontal subdivision

This section illustrates the principles used when combining the longitudinal and horizontal watertight subdivision described in the previous two sections.

Examples are given in figures A-11 and A-12.

To determine the contribution to the attained subdivision index  $A$  – say  $dA$  – for various damage scenarios.

**Examples of multiple horizontal subdivision**

In figure (Hi)

$$dA = p_1 \times s_{min}$$

where:

$s_{min}$  = the lesser of  $s_{12}$  and  $s_2$

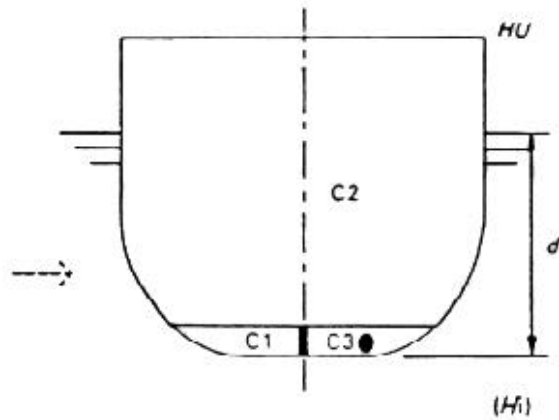

In figure (Hii)

$$dA = p_1 \times [v_1 \times s_{min_1} + (1 - v_1) \times s_{min_2}]$$

where:

$s_{min_1}$  = the lesser of  $s_{12}$  and  $s_2$

$s_{min_2}$  = the lesser of  $s_{123}$  and  $s_{23}$

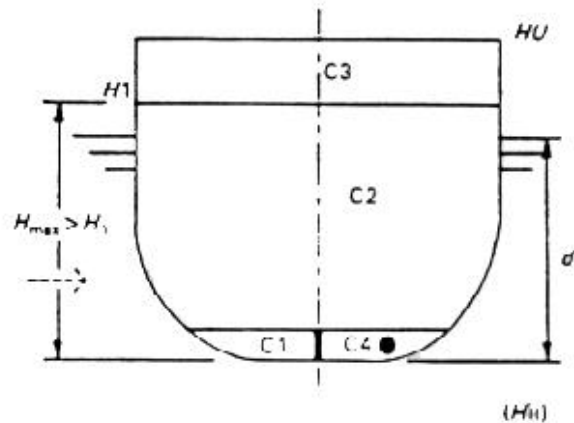

In figure (Hiii)

$$dA = p_1 \times [v_1 \times s_{min_1} + (v_2 - v_1) \times s_{min_2} + (1 - v_2) \times s_{min_3}]$$

where:

$s_{min_1}$  = the lesser of  $s_{12}$  and  $s_2$

$s_{min_2}$  = the lesser of  $s_{123}$  and  $s_{23}$

$s_{min_3}$  = the lesser of  $s_{1234}$  and  $s_{234}$

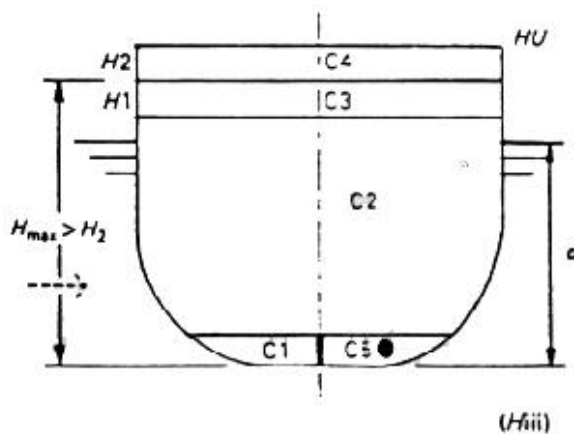

Figure A-10 - Interpretation of multiple horizontal subdivision  
(in all instances,  $r = 1$ )

To determine the contribution to the attained subdivision index  $A$  - say  $dA$  - for various damage scenarios.

**Examples of multiple longitudinal/horizontal subdivision**

In figure (vHfi)

$$dA = p_i \times [r_1 \times s_{\min_1} + (1 - r_1) \times s_{\min_2}]$$

where:

$s_{\min_1}$  = the lesser of  $s_{12}$  and  $s_2$

$s_{\min_2}$  = the lesser of  $s_{123}$  and  $s_2$

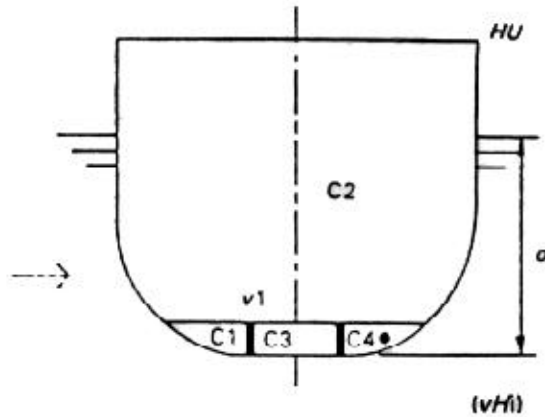

In figure (vHii)

$$dA = p_i \times [r_1 \times s_{\min_1} + (1 - r_1) \times s_{\min_2}]$$

where:

$s_{\min_1}$  = the lesser of  $s_{12}$  and  $s_2$

$s_{\min_2}$  = the lesser of  $s_{123}$  and  $s_2$

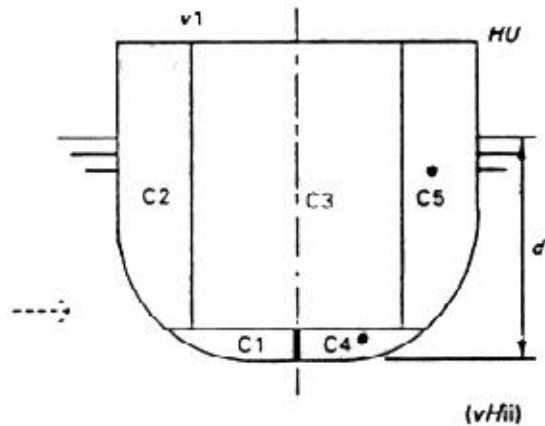

In figure (vHiii)

$$dA = p_i \times [r_1 \times [v_1 \times s_{\min_{11}} + (1 - v_1) \times s_{\min_{12}}] + (1 - r_1) \times [v_2 \times s_{\min_{21}} + (1 - v_2) \times s_{\min_{22}}]]$$

where:

$s_{\min_{11}}$  = the least of  $s_{123}$  and  $s_{23}$  and  $s_3$

$s_{\min_{12}}$  = the least of  $s_{1234}$  and  $s_{234}$  and  $s_{34}$

$s_{\min_{21}}$  = the least of  $s_{123456}$  and  $s_{23456}$  and  $s_{3456}$

$s_{\min_{22}}$  = the least of  $s_{1234567}$  and  $s_{234567}$  and  $s_{34567}$

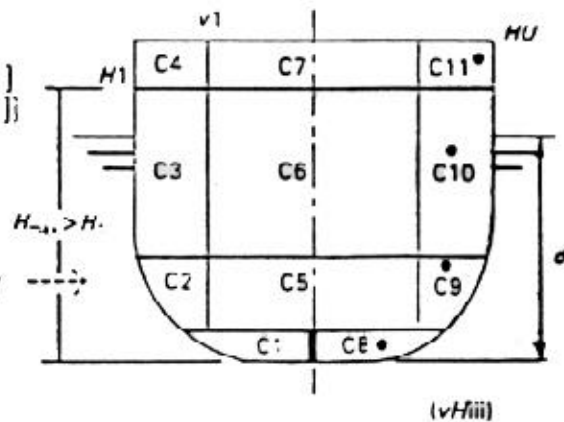

Figure A-11 - Interpretation of combined longitudinal and horizontal subdivision



In figure (vHiv)

$$dA = p_i \times [r_i \times [v_1 \times s_{\min 11} + (1 - v_1) \times s_{\min 12}] + (1 - r_i) \times [v_1 \times s_{\min 21} + (1 - v_1) \times s_{\min 22}]]$$

where:

- $s_{\min 11}$  = the least of  $s_{1234}$  and  $s_{234}$  and  $s_{34}$  and  $s_4$
- $s_{\min 12}$  = the least of  $s_{12345}$  and  $s_{2345}$  and  $s_{345}$  and  $s_{45}$
- $s_{\min 21}$  = the least of  $s_{12345678}$  and  $s_{2345678}$  and  $s_{345678}$  and  $s_{45678}$
- $s_{\min 22}$  = the least of  $s_{123456789}$  and  $s_{23456789}$  and  $s_{3456789}$  and  $s_{456789}$

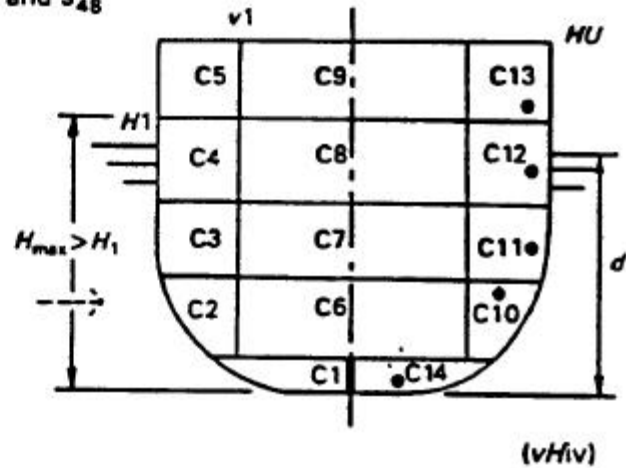

Figure A-12 - Interpretation of combined longitudinal and horizontal subdivision