

U.S.C.G. Merchant Marine Exam

Mate Less than 500-1600 Gross Registered Tons

Q328 Deck Safety

(Sample Examination)

Choose the best answer to the following Multiple Choice Questions.

1. Where is the molded depth measured from on a vessel?

- (A) The inside of the shell
- (B) The outside of the shell
- (C) The top of the garboard stake
- (D) The top of the center vertical keel

If choice A is selected set score to 1.

2. If more than one liferaft is manned after the vessel has sunk, which action will aid in your rescue?

- (A) Each raft should go in a different direction in search of land
- (B) The possibility of a search aircraft finding you is increased by spreading out
- (C) Tie each of the rafts together and try to stay in a single group
- (D) Reduce the number of liferafts by getting as many people as possible into as few rafts as possible

If choice C is selected set score to 1.

3. Where should the sea painter of a lifeboat be secured?

- (A) As close as possible to amidships of the lifeboat
- (B) Secured to the bow of the lifeboat
- (C) Anywhere along the inboard side of the boat
- (D) To the forward thwart on the inboard side

If choice D is selected set score to 1.

4. Fires of which class would most likely occur in the engine room of a vessel?

- (A) Classes A and D
- (B) Classes C and D
- (C) Classes B and C
- (D) Classes A and B

If choice C is selected set score to 1.

5. You board an inflatable liferaft that has been hand launched from a sinking vessel. What should you do FIRST after everyone is onboard the liferaft?

- (A) Ventilate the liferaft of CO₂.
- (B) Operate the radio equipment.
- (C) Cut the painter.
- (D) Open the equipment pack.

If choice C is selected set score to 1.

6. Which term describes the strengthening of damaged bulkheads by using wood or steel?

- (A) Shoring
- (B) Blocking
- (C) Bracing
- (D) Battening

If choice A is selected set score to 1.

7. When the GMDSS Radio Operator on watch hears "SECURITE" spoken three times he can expect to receive a message concerning _____.

- (A) the safety of a vessel or a person is in jeopardy
- (B) a coast station traffic list
- (C) a vessel in need of immediate assistance
- (D) the safety of navigation or important meteorological warnings

If choice D is selected set score to 1.

8. A motor lifeboat shall carry sufficient fuel to operate continuously for a period of which duration?

- (A) 12 hours
- (B) 18 hours
- (C) 24 hours
- (D) 36 hours

If choice C is selected set score to 1.

9. Who issues a ship's radiotelephone station license?

- (A) Maritime Mobile Service Commission
- (B) Radio Technical Commission for Marine Services
- (C) Federal Communications Commission
- (D) U.S. Coast Guard

If choice C is selected set score to 1.

10. All personnel on board a vessel should be familiar with the rescue boat's _____.

- (A) fuel consumption rates
- (B) navigational systems
- (C) maintenance schedules
- (D) boarding and operating procedure

If choice D is selected set score to 1.

11. Which term is given to the fittings used to secure a watertight door?

- (A) Clasps
- (B) Latches
- (C) Dogs
- (D) Clamps

If choice C is selected set score to 1.

12. When should the control of flooding of your vessel be addressed?

- (A) Only if a threat exists
- (B) Following control of fire
- (C) Following restoration of vital services
- (D) First

If choice B is selected set score to 1.

13. How is the "off-load" release system on a survival craft designed to be activated?

- (A) It will activate when there is no load on the cable
- (B) It will activate only when the engine is started
- (C) It will activate only when the doors are closed
- (D) It will activate when there is a load on the cable

If choice A is selected set score to 1.

14. A man aboard a vessel, signaling by raising and lowering his outstretched arms to each side. What does this signal indicate?

- (A) All is clear, it is safe to pass
- (B) A distress signal
- (C) Danger, stay away
- (D) All is clear, it is safe to approach

If choice B is selected set score to 1.

15. Which types of portable fire extinguishers are designed for use on electrical fires?

- (A) Dry chemical and soda-acid
- (B) Dry chemical and carbon dioxide
- (C) Carbon dioxide and foam (stored pressure)
- (D) Foam (stored pressure) and soda-acid

If choice B is selected set score to 1.

16. What is NOT a function of the steam drum of a marine water-tube boiler?

- (A) Holds internal fittings for separation of moisture from steam
- (B) Serves as a reservoir of boiler feedwater
- (C) Receives saturated steam from the generating tubes
- (D) Collects steam exhausted from the turbines

If choice D is selected set score to 1.

17. What does a pyrometer measure on a diesel engine?

- (A) Water pressure
- (B) Exhaust temperature
- (C) Water temperature
- (D) Air box pressure

If choice B is selected set score to 1.

18. In illustration D008SA below, what type of davits are displayed?

- (A) Radial davits
- (B) Gravity davits
- (C) Quadrantal davits
- (D) Round-bar davits

If choice B is selected set score to 1.

19. Which type of weld is used to attach stiffeners to a plate?

- (A) Butt welds
- (B) Seam welds
- (C) Plate welds
- (D) Fillet welds

If choice D is selected set score to 1.

20. The deck beam brackets of a transversely framed vessel resist which stresses?

- (A) Hogging stresses
- (B) Sagging stresses
- (C) Shearing stresses
- (D) Racking stresses

If choice D is selected set score to 1.

21. The spread of fire is NOT prevented by _____.

- (A) cooling surfaces adjacent to the fire
- (B) removing combustibles from the endangered area
- (C) removing smoke and toxic gases by ensuring adequate ventilation
- (D) shutting off the oxygen supply

If choice C is selected set score to 1.

22. Your tankship has 40 gallons of 6% foam concentrate aboard. Approximately how much foam solution can be produced from this supply?

- (A) 200 gallons
- (B) 420 gallons
- (C) 667 gallons
- (D) 986 gallons

If choice C is selected set score to 1.

23. In illustration D016SA below, what number indicates the frapping line?

- (A) 1
- (B) 2
- (C) 3
- (D) 4

If choice B is selected set score to 1.

24. While underway in thick fog you are on watch and hear the cry "man overboard". Which type of maneuver should you make?

- (A) Racetrack turn
- (B) Round turn
- (C) figure eight turn
- (D) Williamson turn

If choice D is selected set score to 1.

25. Which weld fault can only be detected by a method that examines the internal structure of a weld?

- (A) Lack of reinforcement
- (B) Overlap
- (C) Lack of penetration
- (D) Undercut

If choice C is selected set score to 1.

26. When the handle of an all-purpose nozzle is pulled all the way back, it will _____.

- (A) shut off the water
- (B) produce high-velocity fog
- (C) produce a straight stream
- (D) produce low-velocity fog

If choice C is selected set score to 1.

27. You are evacuating crew members from a survival craft that has been adrift in the North Atlantic for several days. What could occur if a person suffering from hypothermia is vertically lifted in a rescue sling to the helicopter?

- (A) A decrease in the symptoms of hypothermia
- (B) Temporary blindness from the altitude change
- (C) Severe shock or cardiac arrest
- (D) Frostbite on exposed areas

If choice C is selected set score to 1.

28. A tank with internal dimensions of 40 feet X 20 feet X 12 feet is pressed with fuel oil weighing 54 pounds per cubic foot. What is the weight, in short tons, of the liquid?

- (A) 135.0 short tons
- (B) 259.2 short tons
- (C) 518.4 short tons
- (D) 11.3 short tons

If choice B is selected set score to 1.

29. The vessel shown in illustration D025DG has broken down and you are going to take her in tow. The wind is coming from her starboard beam. You are making more leeway than she. Where should you position your vessel when you start running lines?

- (A) A
- (B) B
- (C) C
- (D) D

If choice A is selected set score to 1.

- 30.** You are the person in charge of a lifeboat and have made the decision to beach your craft through a heavy surf. Which of the following is the recommended procedure for a boat under oars?
- (A) keep the head into the seas and back smartly to beach the boat in the shortest amount of time
 - (B) keep the head pointed towards the beach, all oars boated to reduce drag, and control the craft with the tiller
 - (C) keep the head pointed toward the beach, deploy the sea anchor from the stern and row steadily
 - (D) keep the head into the seas and deploy the sea anchor to control the speed of advancement to the beach

If choice A is selected set score to 1.

- 31.** Each distress signal and self-activated smoke signal must be replaced not later than the marked date of expiration, or, from the date of manufacture, not later than which time frame?
- (A) 6 months
 - (B) 12 months
 - (C) 24 months
 - (D) 42 months

If choice D is selected set score to 1.

- 32.** Which type of portable fire extinguishers is NOT designed for use on flammable liquid fires?
- (A) Carbon dioxide
 - (B) Dry chemical
 - (C) Foam
 - (D) Water (cartridge-operated)

If choice D is selected set score to 1.

- 33.** What is the primary danger when dealing with a helicopter fire?
- (A) Loss of stability
 - (B) Heat damage to helicopter structure
 - (C) Burning jet fuel running on to quarters or other areas
 - (D) Rotating and flying debris

If choice C is selected set score to 1.

- 34.** Inflatable liferafts are provided with which item?
- (A) A towing bridle
 - (B) An oil lantern
 - (C) A compass
 - (D) Canned milk

If choice A is selected set score to 1.

35. How should the letter "D" be pronounced when spoken on the radiotelephone?

- (A) DA VID
- (B) DELL TAH
- (C) DOG
- (D) DUKE

If choice B is selected set score to 1.

36. Which is the best action to take when plugging holes below the waterline for the safety of the vessel?

- (A) Eliminate all water entering the hole
- (B) Reduce the entry of water as much as possible
- (C) Plug the largest holes first
- (D) Only plug holes in machinery or other vital spaces

If choice B is selected set score to 1.

37. You are using a racetrack turn to recover a man overboard. The vessel is first steadied when how many degrees away from the original heading?

- (A) 60° to 70°
- (B) 90°
- (C) 135°
- (D) 180°

If choice D is selected set score to 1.

38. If you are fighting a fire below the main deck of your vessel, which action is most important concerning the stability of the vessel?

- (A) Maneuvering the vessel so the fire is on the lee side
- (B) Shutting off electricity to damaged cables
- (C) Removing burned debris from the cargo hold
- (D) Pumping fire-fighting water overboard

If choice D is selected set score to 1.

39. During a training exercise a submarine indicating that a torpedo has been fired will send up smoke from a float. What color will the smoke be?

- (A) Black
- (B) Orange
- (C) Yellow
- (D) Red

If choice A is selected set score to 1.

40. When approaching a fire from leeward you should shield firefighters from the fire by using _____.

- (A) a straight stream of water
- (B) high-velocity fog
- (C) low-velocity fog
- (D) foam spray

If choice B is selected set score to 1.

41. What does the lifesaving signal indicated by a horizontal motion of a white light or white flare mean?

- (A) "Negative"
- (B) "Landing here highly dangerous"
- (C) "Avast hauling"
- (D) All of the above

If choice D is selected set score to 1.

42. Which of the following aspects of a flooded space will most adversely affect transverse stability if it is subject to free communication?

- (A) Off-center
- (B) Completely flooded
- (C) Open to the sea above and below the waterline
- (D) On the centerline

If choice A is selected set score to 1.

43. You are using an oxygen indicator. How long should you wait after the sample is drawn into the instrument before reading the meter?

- (A) At least 20 seconds
- (B) No wait is necessary, the reading occurs immediately.
- (C) At least 10 seconds
- (D) At least 5 seconds

If choice C is selected set score to 1.

44. What is the purpose of a striker plate?

- (A) Provides surface for applying force on machinery
- (B) Absorbs machinery vibration
- (C) Prevents valve stem over-travel
- (D) Provides landing surface for the sounding bob

If choice D is selected set score to 1.

45. Which is the BEST method of applying foam to a fire?

- (A) Sweep the fire with the foam
- (B) Spray directly on the base of the fire
- (C) Spray directly on the surface of the fire
- (D) Flow the foam down a nearby vertical surface

If choice D is selected set score to 1.

46. A weight of 1,000 short tons is equivalent to _____.

- (A) 2,000 kips
- (B) 2,240 long tons
- (C) 1,500 foot-pounds
- (D) 2,000 pounds

If choice A is selected set score to 1.

47. Your vessel is conducting helicopter evacuation operations for an injured crew member. Which of the following statements is true concerning the hoisting line?

- (A) A tag line is required to be attached to the hoist cable for securing
- (B) As a safety measure wrap the line around the patient before attaching it to the basket
- (C) Allow the line to touch the deck to discharge the static electricity
- (D) Secure the graining line to the deck railings

If choice C is selected set score to 1.

48. What does the gross tonnage of a vessel indicate?

- (A) Total weight including cargo
- (B) Volume in cubic feet
- (C) Displacement in metric tons
- (D) Draft in feet

If choice B is selected set score to 1.

49. What statement about immersion suits is TRUE?

- (A) Any tear or leak will render the suit unserviceable and it must be replaced.
- (B) No stowage container for immersion suits may be capable of being locked.
- (C) During the annual maintenance, the front zipper should be lubricated using light machine oil or mineral oil.
- (D) Immersion suits should be worn while performing routine work on deck.

If choice B is selected set score to 1.

50. The distress message of a ship should include considerable information which might facilitate the rescue. Which is TRUE concerning the information?

- (A) The information should be transmitted as a series of short messages, if time allows
- (B) The message must be sent to a Coast Guard station FIRST
- (C) The distress message shall include the vessel's draft
- (D) The information is ALWAYS included in the initial distress message and repeated as required

If choice A is selected set score to 1.

51. How often are each EPIRB and SART for lifeboats required to be tested on the vessel?

- (A) Weekly
- (B) Every 2 weeks
- (C) Monthly
- (D) Every 3 months

If choice C is selected set score to 1.

52. You are approaching a ship that is broken down and are preparing to take her in tow. BEFORE positioning your vessel to pass the towline, which action should you take?

- (A) Install chafing gear on the towline
- (B) Compare the rate of drift between the ships
- (C) Secure the bitter end of the towing hawser to prevent loss if the tow is slipped
- (D) Have traveling lizards rigged to guide the towline while it is paid-out

If choice B is selected set score to 1.

53. Convection spreads a fire by _____.

- (A) burning liquids flowing into another space
- (B) heated gases flowing through ventilation systems
- (C) the transfer of heat across an unobstructed space
- (D) transmitting the heat of a fire through the ship's metal

If choice B is selected set score to 1.

54. To reduce the number of strakes at the bow, two strakes are tapered and joined at their ends by a single plate. What is the name of this plate?

- (A) Joiner
- (B) Cover plate
- (C) Stealer plate
- (D) Lap strake

If choice C is selected set score to 1.

55. Which statement is TRUE concerning a fire in a machinery space?

- (A) The space should be opened 5 minutes after flooding CO₂ to prevent injury to personnel
- (B) Water in any form should not be used as it will spread the fire
- (C) The fixed carbon dioxide system should be used immediately, as it is the most efficient means of extinguishment
- (D) The fixed carbon dioxide system should be used only when all other means of extinguishment have failed

If choice D is selected set score to 1.

56. You are proceeding to a distress site and expect large numbers of people in the water. Which statement is TRUE?

- (A) You should stop to windward of the survivors in the water and only use the ship's boats to recover the survivors.
- (B) An inflatable liferaft secured alongside can be an effective boarding station for transfer of survivors from the boats.
- (C) Survivors in the water should never be permitted alongside due to the possibility of injury from the vessel.
- (D) If the survivors are in inflatable rafts you should approach from windward to create a lee for the survivors.

If choice B is selected set score to 1.

57. After the boat is at the top of the davit heads, the davit arms begin moving up the tracks and are stopped by the _____.

- (A) brake handle
- (B) hoist man
- (C) limit switch
- (D) preventer bar

If choice C is selected set score to 1.

58. What is the effect of spreading oil on the open sea?

- (A) Lengthening the distance between successive crests
- (B) Preventing the wave crests from breaking
- (C) Diminishing the height of the seas
- (D) Increasing the height of the seas

If choice B is selected set score to 1.

59. Which statement describes the relationship between flash point and auto-ignition temperature?

- (A) They are not necessarily related.
- (B) Both are higher than normal burning temperatures.
- (C) The flash point is always higher.
- (D) The ignition temperature is always higher.

If choice D is selected set score to 1.

60. You are at sea and have received a General Emergency message announcing the outbreak of war in Europe. You are directed to comply with the instructions in NGA (NIMA) PUB 117, Chapter Eight. Which statement is TRUE?

- (A) When over 200 miles from a port in the danger zone, you should not darken ship.
- (B) If on a coastwise voyage along the east coast of the U.S., you should put into the nearest port.
- (C) You should attempt to submit an AMVER report to NSA.
- (D) You should only enter a port in the danger zone during hours of darkness.

If choice C is selected set score to 1.

61. Accumulations of oily rags should be _____.

- (A) kept in nonmetal containers
- (B) cleaned thoroughly for reuse
- (C) discarded as soon as possible
- (D) kept in the paint locker

If choice C is selected set score to 1.

62. Which is TRUE concerning the painter of an inflatable liferaft?

- (A) Stowed under the raft to protect from the elements
- (B) Secured to permanent object on deck via weak link
- (C) Faked out next to the case on deck
- (D) Staged for free running on the deck

If choice B is selected set score to 1.

63. For the purpose of training and drills, if reasonable and practicable, how frequently should rescue boats be launched with their assigned crew?

- (A) Once a month
- (B) Twice a year
- (C) Once a week
- (D) Once a year

If choice A is selected set score to 1.

64. Which is required to be marked on the vessel's life preservers?

- (A) The crew member's article number
- (B) The vessel's name
- (C) The vessel's home port
- (D) The stowage space assigned

If choice B is selected set score to 1.

65. Before using a fixed CO2 system to fight an engine room fire, you must _____.

- (A) secure the engine room ventilation
- (B) secure the machinery in the engine room
- (C) evacuate all engine room personnel
- (D) All of the above

If choice D is selected set score to 1.

66. A 750 foot passenger vessel operating on the Great Lakes, not subject to SOLAS regulations, is required to carry how many ring life buoys?

- (A) 24
- (B) 18
- (C) 12
- (D) 6

If choice A is selected set score to 1.

67. If you must enter water on which there is an oil fire, you should _____.

- (A) keep both hands in front of your face to break the water surface when diving head first
- (B) wear very light clothing
- (C) protect your life preserver by holding it above your head
- (D) enter the water on the windward side of the vessel

If choice D is selected set score to 1.

68. You are picking up an unconscious person that has fallen overboard in a fresh breeze. For safety reasons how should a small craft approach?

- (A) With the wind on your starboard side
- (B) With the victim to leeward
- (C) With the victim to windward
- (D) With the wind on your port side

If choice C is selected set score to 1.

69. When electrical equipment is involved in a fire, where should the stream of dry chemicals be directed?

- (A) Fogged above the equipment
- (B) Shot off a flat surface onto the flames
- (C) Aimed at the source of the flames
- (D) Used to shield against electrical shock

If choice C is selected set score to 1.

70. You are tending the lifeline of a person who has entered a compartment wearing a breathing apparatus. How many tugs of the lifeline mean "Are you all right"?

- (A) One
- (B) Two
- (C) Three
- (D) Four

If choice A is selected set score to 1.

D025DG

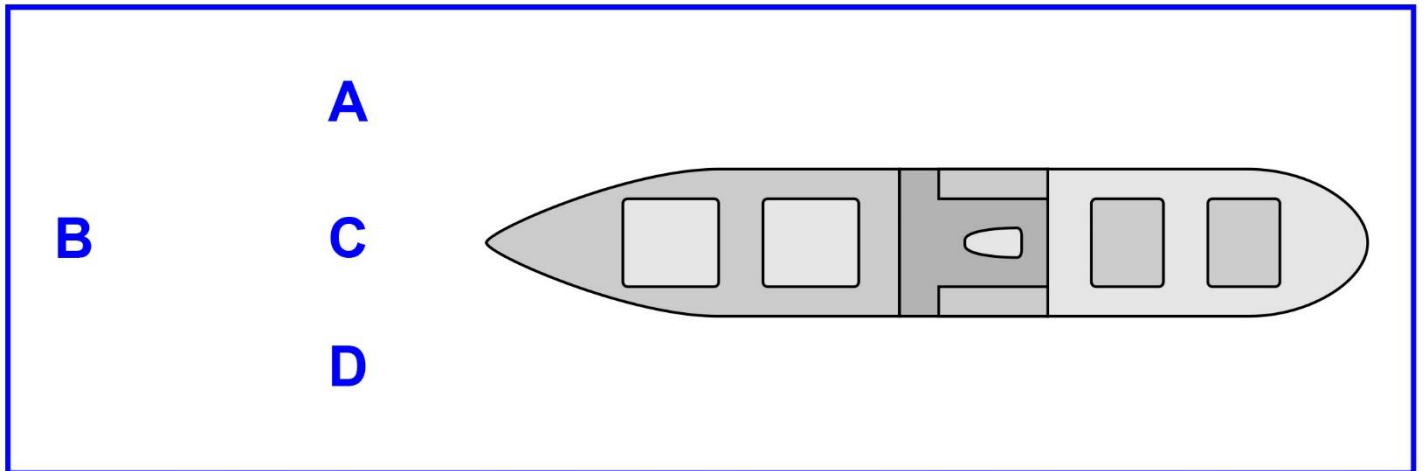

D008SA

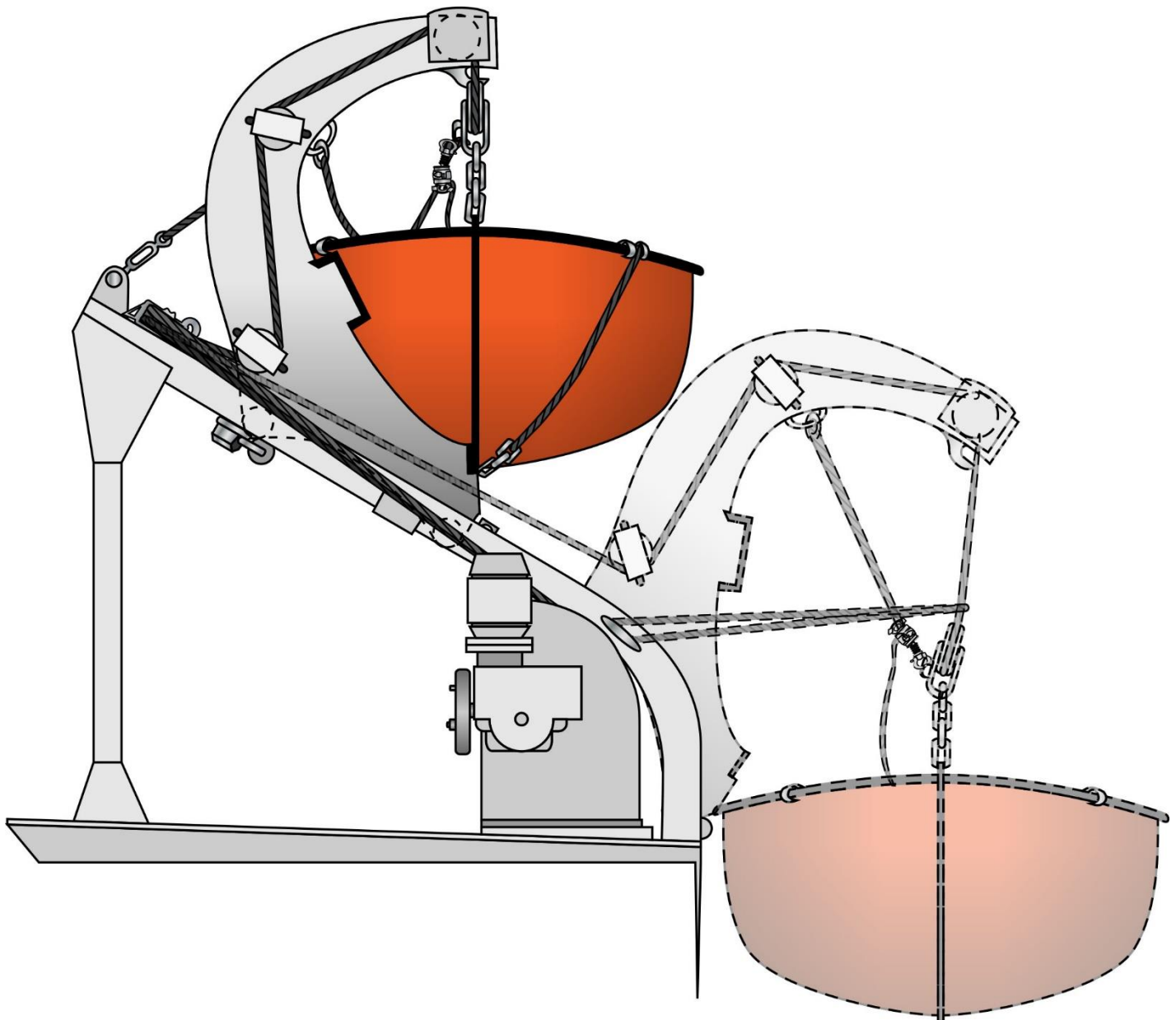

Adapted for testing purposes only from HAYLER, American Merchant Seaman's Manual, 7th edition
Copyright © 2003 by Cornell Maritime Press, Inc.

Further reproduction prohibited without permission

D016SA

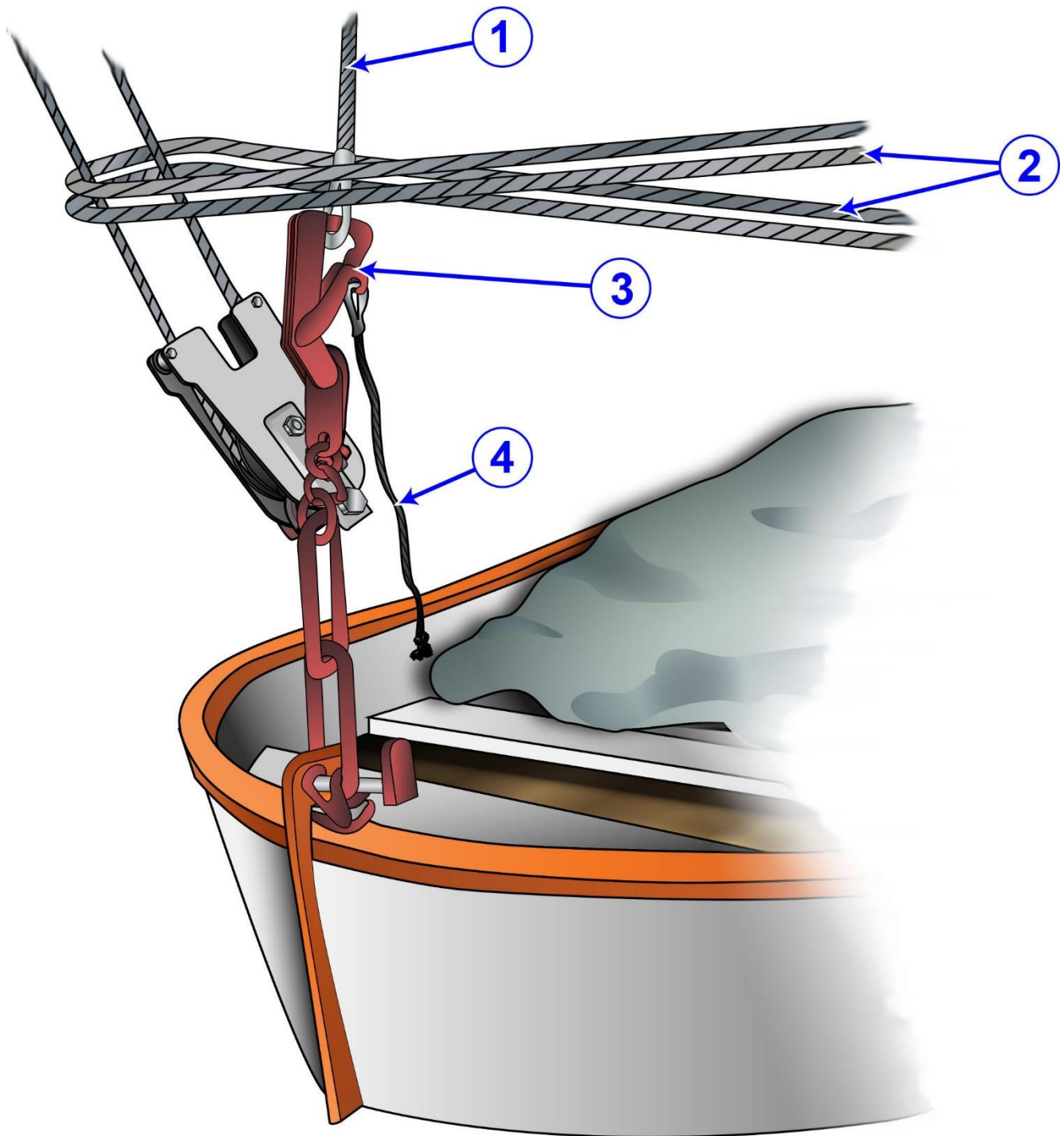

Adapted for testing purposes only from Water Survival Manual
Copyright © 1991 by Seafarers Harry Lundeberg School of Seamanship
Further reproduction prohibited without permission